

WEP-80 Wide Belt Elevating Prefeeder

Product Overview:

The WEP-80 wide belt elevating prefeeder is specially designed to handle large parts. Two independently controlled variable speed drives ensure gentle product metering. Designed for floor level parts loading, the 80 ft³ capacity hopper delivers product at an average belt speed of 23 feet per minute. The cleated elevator belt has a nominal cleat height of 4" and a cleat pitch of 12", allowing for maximum product loading. Note: Controllers and mechanical level sensors are not supplied with this unit.



Part Number	WE8022XDSA	WE8022XASA
Motor Style	DC	AC
Motor Voltage	90V	230/460V
Horsepower (Horizontal)	1/2hp	1/2hp
Horsepower (Elevator)	1/2hp	1/2hp
Total Equipment Weight	2462 lbs. / 1117 kg	
Hopper Capacity	80 ft ³ / 2266 liters	

Standard Features:

- Stainless steel construction
- Sensor controlled dual belt metering system
- Horizontal belt is FDA/USDA approved white buna-n/polyester polyflake endless belting
- Elevator belt is FDA/USDA approved white 1-ply solid woven polyester fabric with .156" thick white PVC coating and PVC cleats

Available Options:

- Elevator extensions*
- Continuous welded hopper seams
- Elevator/Hopper covers
- Washdown motor
- NEMA 1 encased controller
- Clean out doors
- Casters

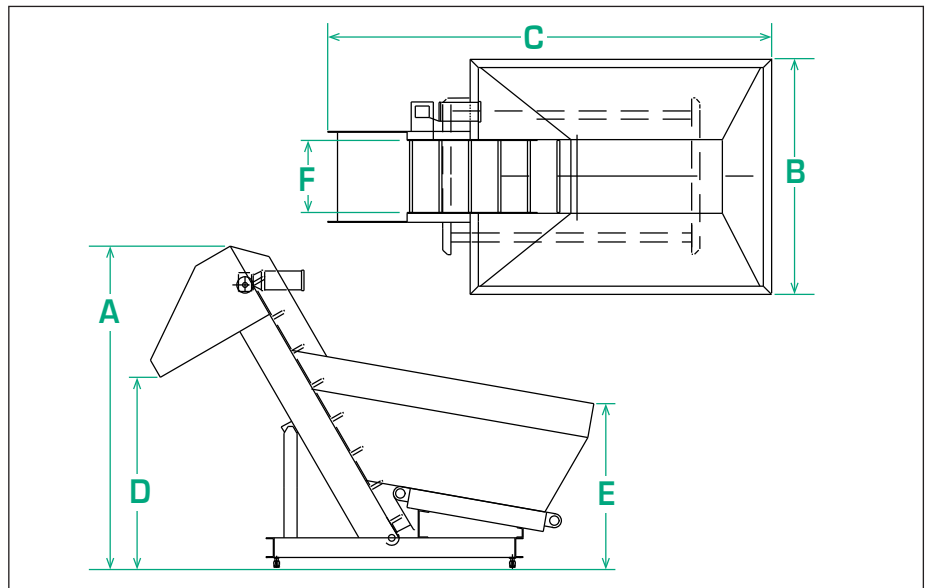

Product Specifications	ANSI	Metric
A Overall Height	100.00"	2540mm
B Overall Width	72.00"	1829mm
C Overall Length	136.00"	3454mm
D Discharge Height	60.00"	1524mm
E Hopper Load Height	50.00"	1270mm
F Belt Width (Elevator)	22.00"	559mm

* It is strongly recommended that the frame of the prefeeder be reinforced and/or additionally supported for elevator extensions of 72" or greater.