



Product Overview:

Shibuya Hoppmann's WB-6 prefeeder is specially designed to handle fragile parts. Two independent variable speed drives and a standard level sensor ensures gentle product metering. Product drops from the upper belt to the lower belt where it is pulled away at a faster rate to assist in part separation and de-tangling. Note: Controllers and mechanical level sensors are not supplied with this unit.

Part Number	WB06XXXDSA	WB06XXXASA
Motor Style	DC	AC
Motor Voltage	90V	220/380V
Upper Belt Horsepower	1/2hp	1/2hp
Lower Belt Horsepower	1/30hp	1/4hp
Total Equipment Weight	650 lbs. / 295 kg	
Supply Hopper Capacity	6 ft ³ / 170 liters	

Standard Features:

- Stainless steel construction
- Adjustable feed angle
- Sensor controlled dual belt metering system
- FDA/USDA approved white buna-n/ polyester polyflake endless belting (upper belt)
- Durable reinforced black neoprene belt with fiberglass cord (lower belt)

Available Options:

- Continuous welded hopper seams
- Washdown motor
- NEMA 1 encased controller
- Hopper covers
- Casters

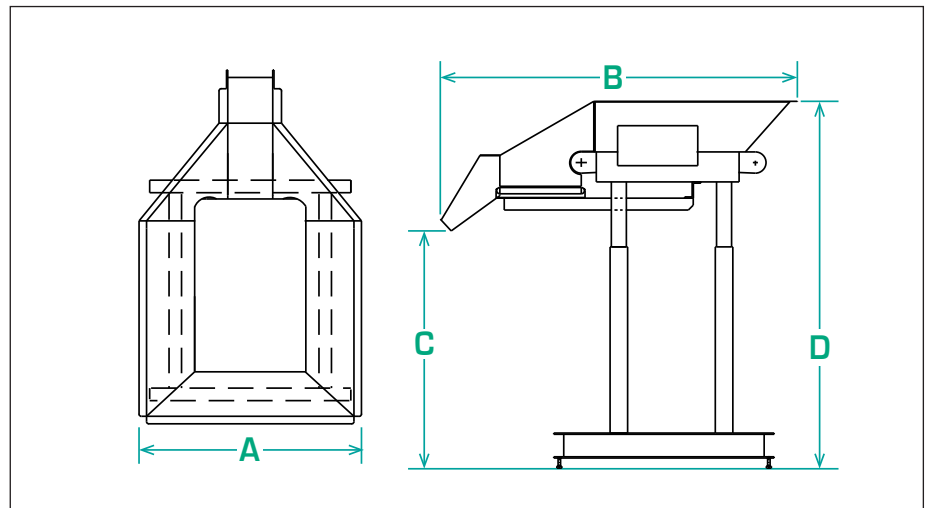

Product Specifications		ANSI	Metric
A	Overall Width	51.00"	1295mm
B	Overall Length	72.00"	1829mm
C	Discharge Height (Adjustable)	48.00" ± 10.0"	1219 ± 254mm
D	Load Height (Adjustable)	74.00" ± 10.0"	1880 ± 254mm
E	Angle of Feed	0° - 11°	0° - 11°