



*Shown with optional stand, motor and custom chute.

Product Overview:

The Shibuya Hoppmann EC-Series Bulk Product Conveyor can be used as a bulk conveying system or can be modified to accommodate a bulk hopper for any prefeeding need. This low cost conveyor uses formed edge product rails which are slotted to adjust the amount of clearance between the belt cleats and the side walls, rugged 3/8" thick belt cleats for heavy duty applications, and a product well at the base to prevent parts from falling. Conveyor speeds of over 60 feet per minute can be achieved, allowing for the movement of large quantities of parts.

Part Number	EC0812MDSA	EC0812MASA
Motor Style	DC	AC
Motor Voltage ¹	90V	230/460V
Horsepower	1/2hp	1/2hp
Total Equipment Weight ²	500 lbs. / 227 kg	

¹ Motor is optional.

² Dependent upon length.

Standard Features:

- 304 stainless steel construction
- Four (4') foot through twelve (12') foot lengths available in 1 foot increments
- 4.00" diameter pulleys
- FDA/USDA white PVC belt with heavy duty 2" tall cleats
- Adjustable formed edge product rails
- Direct drive, side mount reducer (can be mounted on either side)

Available Options:

- DC/AC motors available in 90VDC, 115VAC, 230VAC and 460VAC
- Stainless steel support stand
- Washdown bearings
- Longer conveyor lengths
- Other cleat pitches available
- Custom chutes available

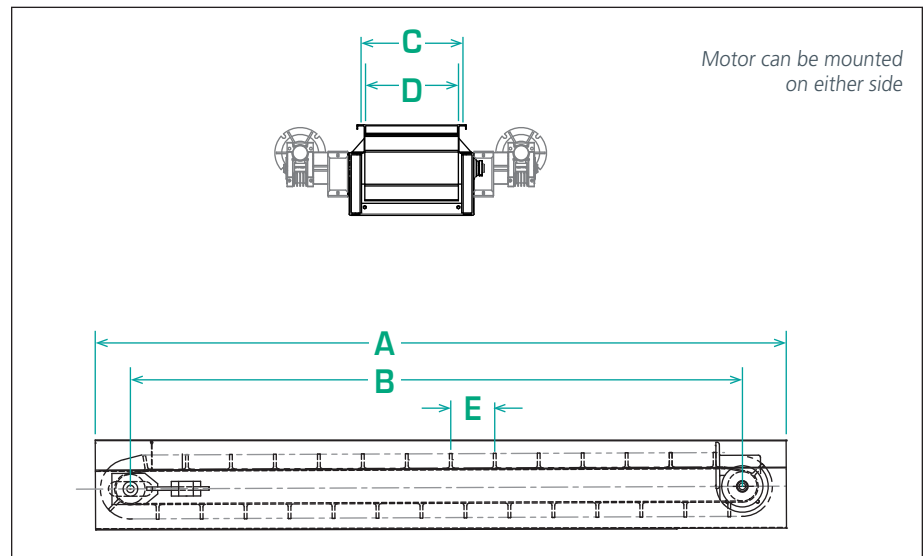

Product Specifications		ANSI	Metric
A	Overall Length of Channel	5' (60") - 13' (156")	1524mm - 3963mm
B	Pulley Center Distance	4' (48") - 12' (144")	1219mm - 3658mm
C	Channel (Bed) Width	16.00"	406mm
D	Belt Width	12.00"	305mm
E	Cleat Pitch (Standard)	12.00"	305mm