

## Model LB Series Overhead Prefeeder

### ANSI/Metric Installation & Maintenance Manual

Refer all servicing to qualified personnel.

This manual is intended for use by qualified mechanics and electricians who install or service the Hoppmann LB Series Overhead Prefeeder.



Record your serial plate information  here for future reference

Model Number	Serial Number/Date

Publications Edition, Revision 4, All Rights Reserved.  
Copyright 2015 by Shibuya Hoppmann Corporation.

Duplication of this manual, in whole or in part, requires prior written consent from Shibuya Hoppmann Corporation.

#### Headquarters

7849 Coppermine Drive  
Manassas, VA  
20109  
540.829.2564 t  
800.368.3582 t  
540.829.1726 f

#### Sales

1445 Brookville Way  
Suite F  
Indianapolis, IN 46239  
317.322.0754 t  
800.368.3582 t  
317.322.0794 f

#### Manufacturing

291 Dillard Road  
Madison Heights, VA  
24572  
434.929.4746 t  
800.543.0915 t  
434.929.4959 f

---

# Quick Start

## Thank You for Choosing Shibuya Hoppmann

Thank you for purchasing a system from Shibuya Hoppmann. Our prefeeders, feeders, and automated systems possess an industry-wide reputation of excellence for their quiet and rapid handling of parts, ease of use and low maintenance requirements.

## About This Manual

### Assumptions

Shibuya Hoppmann Corporation assumes that all procedures contained in this manual will be performed by a qualified mechanic or electrician who must install or service the LB-Series prefeeders. All procedures in this manual should be performed by qualified personnel or under their direction.

### Models Covered

This manual covers three (3) styles of prefeeders models: **LB-01 Overhead Prefeeder, LB-03 Overhead Prefeeder, or the LB-06 Overhead Prefeeder.** If you are unsure of your model, locate the inventory number on the serial plate of your prefeeder.

## Before You Start

### Tools You Will Need

The LB Series prefeeders are both "soft ANSI" and metric construction, meaning that metric threads and hardware are used throughout. The prefeeders require metric tools for repair and/or adjustment.

---

### Equipment Improvements & Document Revisions Notice

Shibuya Hoppmann Corporation (SHC) continually improves its products, and reserves the right to change or discontinue specifications and designs shown in this manual without notice and without incurring obligation. Occasionally older versions of equipment may have different spare parts/replacement parts requirements. Please be sure to contact SHC before ordering specific parts for older style prefeeders. SHC has made every effort to verify the information contained in this manual, but reserves the right to correct any error at the time of the manual's next revision. 4.2015.

---

# Important - Read First

## Caution Symbols & Messages

### Caution Symbols and Messages

Caution symbols and messages in this manual call attention to hazardous voltages, moving parts, and other hazardous conditions. Please understand what the different warning labels and indicators refer to and how to avoid possible injury and/or damage to personnel and equipment.



The lightning bolt symbol serves as a caution to denote possible personal injury and/or damage to the equipment due to electrical hazards.



The exclamation point symbol serves as a caution to denote possible personal injury and/or damage to the equipment.

## Danger - Electrical/Voltage Hazard



The voltages in this system can cause death or serious injury. **Service should be performed only by qualified service personnel.** Read the safety precautions in Chapter 2 before operating or servicing this system, including any Lockout/Tagout procedures.

## Danger - Mechanical Hazard



To reduce the risk of injury from moving parts, keep all safety covers in place, secure loose clothing, and wear safety glasses or other protective eye wear when operating machine.



To reduce the risk of injury from moving parts, padlock and tag the main electrical and pneumatic disconnects before adjusting or replacing change parts or performing mechanical maintenance. Ensure that power is off and cannot be reactivated accidentally.

# Table of Contents

<b>Chapter Name</b>		<b>Page</b>
<b>Quick Start</b>	About this Manual	2
	Before You Start	2
	Caution Symbols and Messages	3
	Table of Contents	4
<hr/>		
<b>1</b>		
<b>Description and Specifications</b>	The LB Series Overhead Prefeeder: Overview	7
	LB-01 Overhead Prefeeder Specifications	8
	LB-03/06 Overhead Prefeeder Specifications	10
	<b>Figures:</b>	
	Figure 1-1. LB-03 Overhead Prefeeder (DC Motor) - Exploded View	6
	Figure 1-2. LB-01 Overhead Prefeeder	7
	Figure 1-3. LB-03 Overhead Prefeeder (with Support Stand)	7
	Table 1-1. LB-01 Specifications	8
	Figure 1-4. LB-01 Dimension Views	9
	Table 1-2. LB-01 Dimension Specifications	9
	Table 1-3. LB-03/06 Specifications	10
	Figure 1-5. LB-03/06 Dimension Views	11
	Table 1-4. LB-03/06 Dimension Specifications	11
<hr/>		
<b>2</b>		
<b>Safety Precautions</b>	Safety Precautions	13
	Specific Warnings & Cautions	13
	Operating and Maintenance: Do's and Don'ts	13
<hr/>		
<b>3</b>		
<b>Installation &amp; Start-Up</b>	If the Prefeeder is Already Set Up	15
	Unpacking and Inspection	15
	Physical Setup	16
	Installing Hopper Extensions	17
	Level Sensor	18
	Establishing the Correct Prefeeder Speed	18
	<b>Figures:</b>	
	Figure 3-1. Sample Serial Plate	15
	Figure 3-2. Hopper Extension for LB-03	17
	Figure 3-3. Optical Bowl Level Sensor (Optional)	18
	Figure 3-4. Mechanical Bowl Level Sensor (Optional)	18

---

<b>4</b>	<b>Chapter Name</b>	<b>Page</b>
	<b>Preventive Maintenance</b>	
	Belt/Drive Assembly	19
	Replacing the Belt	19
	Gear Motor Maintenance	20
	Routine Cleaning	21
	Figures:	
	Figure 4-1. Belt/Drive Assembly (with DC Motor)	19
<b>5</b>	<b>Replacement Parts</b>	
	Replacement Parts	23
	LB-01 Overhead Prefeeder	24
	LB-03/06 Overhead Prefeeder	25
	Figures:	
	Figure 5-1. Sample Serial Plate	23
<b>6</b>	<b>Warranty</b>	
	Warranty	27

---

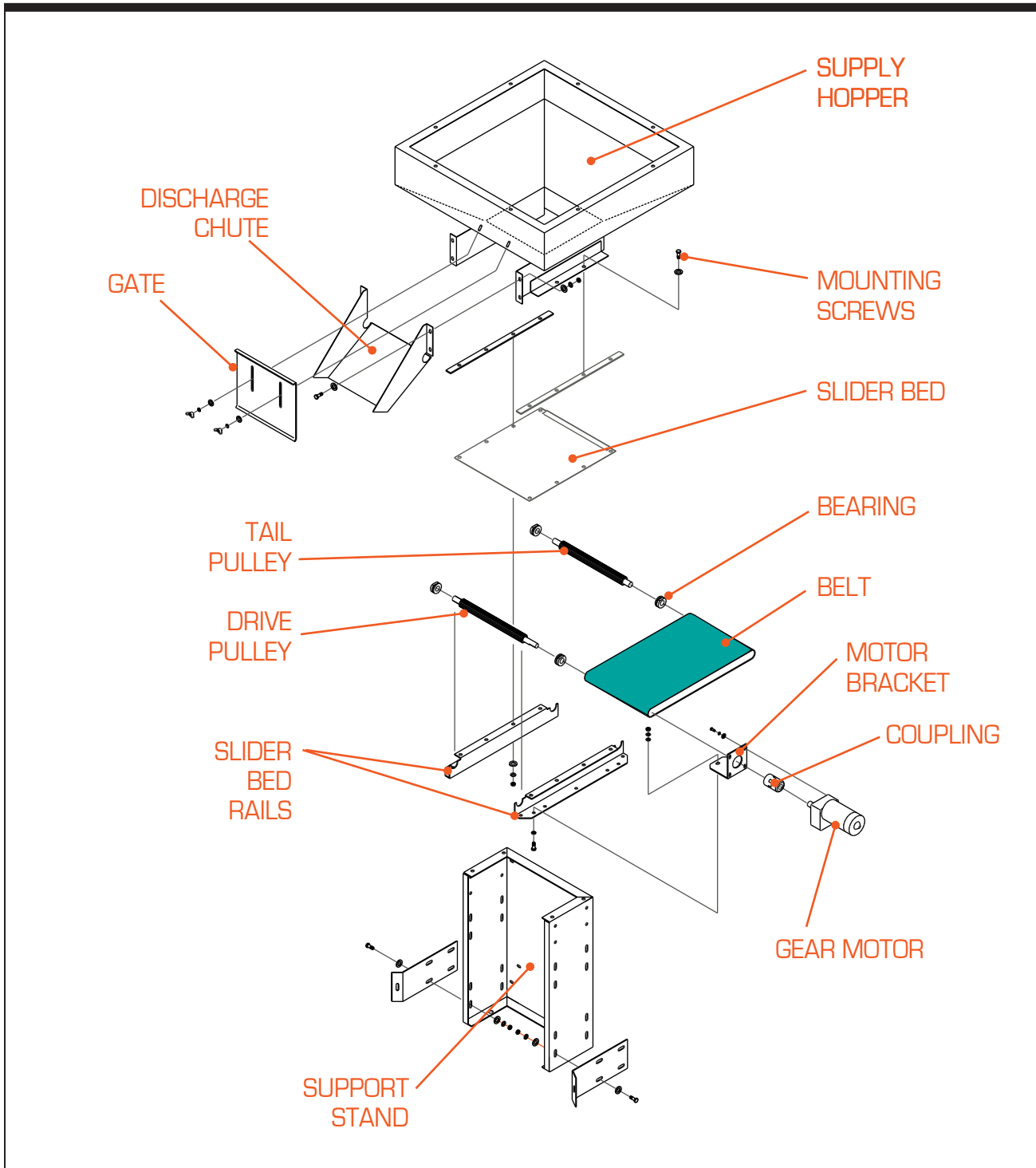

Figure 1-1. LB-03 Overhead Prefeeder (DC Motor) - Exploded View

# Description & Specifications

## 1

### The LB Series Overhead Prefeeder: Overview

**Function** The LB Series overhead prefeeders are designed to load small to medium parts and are engineered to interface directly with smaller style feeders. The LB-01 prefeeder (Figure 1-2) has a 1 cubic foot hopper, while the LB-03 (Figure 1-3) and LB-06 have a 3 and 6 cubic foot hopper, respectively. See Figure 1-1 for an exploded view of the LB-03.

**Operation of Equipment** Product is loaded into a supply hopper. The product then passes through the gate which meters the flow of parts from the prefeeder. Product is then metered into either the recipient feeder bowl or other equipment.

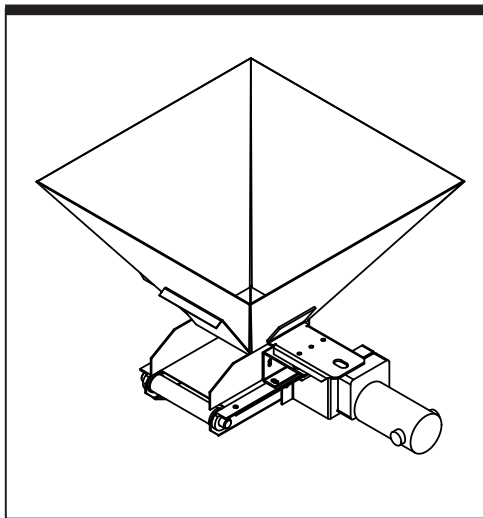

Figure 1-2. LB-01 Overhead Prefeeder

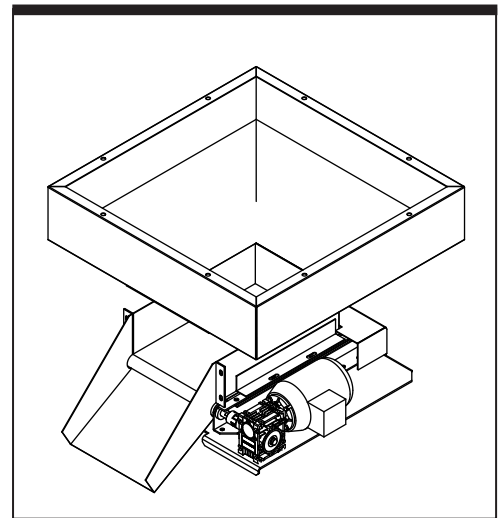

Figure 1-3. LB-03 Overhead Prefeeder  
(Without Support Stand)

## LB-01 Overhead Prefeeder Specifications

**Standard Features** The standard LB-01 overhead prefeeder is specially designed to handle small parts and is engineered to interface directly with smaller style parts feeders. A variable speed motor drives the belt at a speed of 23.00" per minute. The LB-01 is constructed of stainless steel and comes standard with a durable reinforced black neoprene belt with fiberglass cord.

**Optional Features** Optional features include continuous welded seams, hopper covers, a NEMA 1 encased controller, and/or a neoprene USDA/ FDA dry contact food grade belt with fiberglass cord.

**Specifications** Please refer to the tables below for LB-01 specifications:

Specifications	DC
Motor Size	1/30hp
Supply Voltage	90V
Average Belt Speed	23" / minute
Hopper Capacity	1 ft <sup>3</sup> / 28.32 liters

Table 1-1. LB-01 Specifications



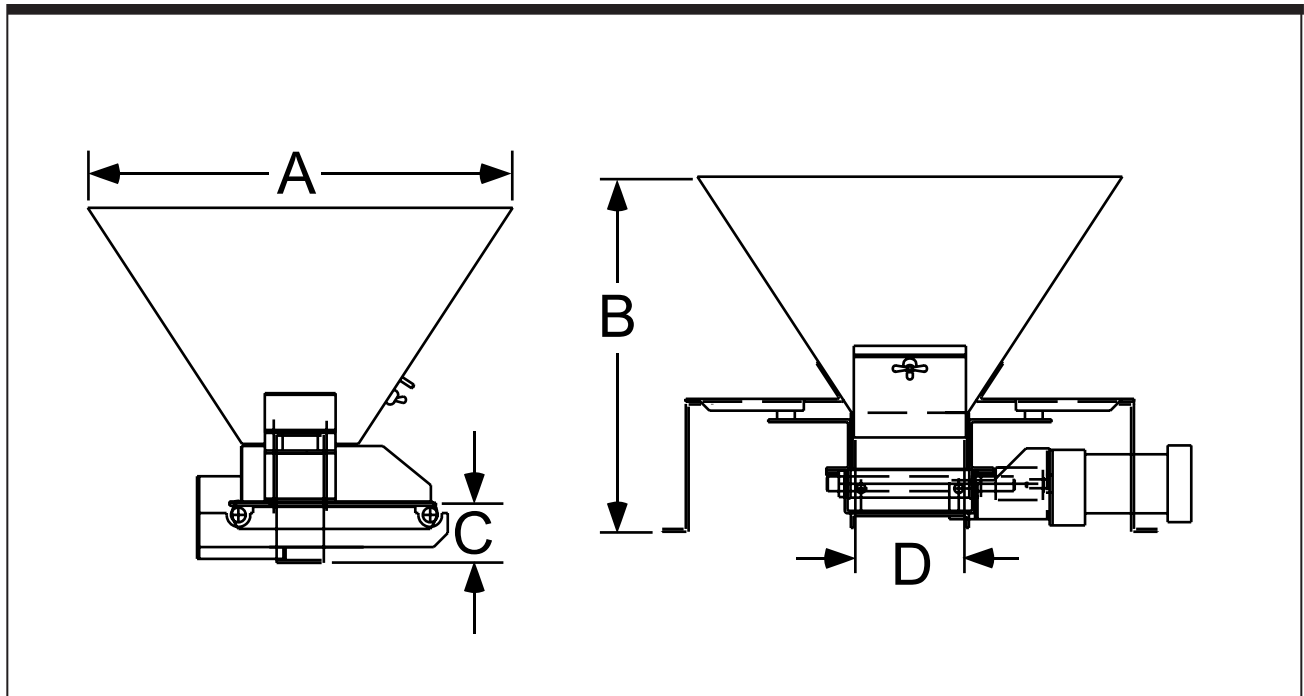

Figure 1-4. LB-01 Overhead Prefeeder

Dimension Specifications		ANSI	Metric
A	Hopper Width and Length	17.93" x 17.93"	455.4 x 455.4mm
B	Overall Height	15.35"	389.9mm
C	Discharge Height	2.83"	71.9mm
D	Belt Width	5"	127mm
Overall Weight		35 lbs.	16 kg

Table 1-2. LB-01 Dimension Specifications

## LB-03/06 Overhead Prefeeder Specifications

**Standard Features** The standard LB-03/06 overhead prefeeder is designed to handle small to medium sized parts and is engineered to interface directly with smaller style parts feeders. A variable speed motor drives the belt at a speed of 23.00" per minute. The LB-01 is constructed of stainless steel and comes standard with a durable reinforced black neoprene belt with fiberglass cord.

**Optional Features** Optional features include continuous welded seams, hopper covers, a NEMA 1 encased controller, and/or a neoprene USDA/ FDA dry contact food grade belt with fiberglass cord.

**Specifications** Please refer to the tables below for LB-03/06 specifications:

Specifications	DC	AC
Motor Size	1/30hp	1/8ph
Supply Voltage	90VDC	208-230/460V
Average Belt Speed	23"	10.67 meters/min.
LB-03 Hopper Capacity	3 ft <sup>3</sup>	85 liters
LB-06 Hopper Capacity	6 ft <sup>3</sup>	170 liters

Table 1-3. LB-03/06 Specifications

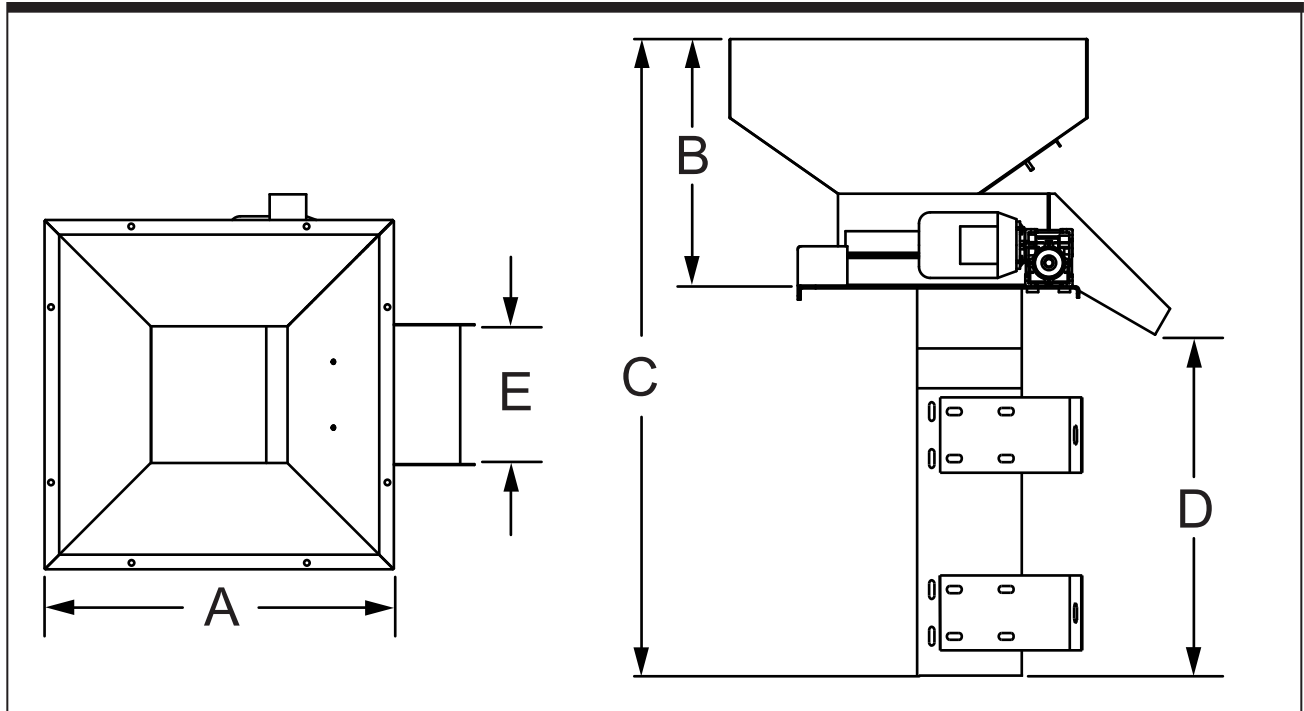

Figure 1-5. LB-03/06 Dimension Views

Dimension Specifications		ANSI	Metric
A	Hopper Width and Length	23.87" x 23.87"	606.3 x 606.3mm
B	Overall Height - LB-03	37"	949.5mm
B	Overall Height - LB-06	47.38"	1203.5mm
C	Discharge Height	17.62"	447.5mm
D	Belt Width	9.97"	253.2mm
Overall Weight		110 lbs.	50 kg

Table 1-4. LB-03/06 Dimension Specifications

## Notes

---

# Safety Precautions

## 2

### Safety Precautions

This prefeeder has been designed to be as safe as possible for operators. However, even well-built machines can be installed or operated in a hazardous manner. Safety precautions must be observed by users.

### Specific Warnings & Cautions



**Turn Power Off!** Before servicing the prefeeder, make sure you have turned off compressed air and electrical power in a way that prevents accidental reactivation. Padlock, and clearly tag, the appropriate electrical and pneumatic disconnects. Lockout/Tagout procedures are covered in the United States Code of Federal Regulation (CFR), Title 29, Part 1910.147, "The Control of Hazardous Energy."



**Dress Properly.** To reduce the risk of injury from moving parts, secure loose clothing. Do not wear jewelry or neckties near the prefeeder. Wear safety glasses or other protective eye wear when operating or performing maintenance on the prefeeder. Never place hands or tools in the prefeeder while it is operating.



**Install Safety Covers.** Make sure the prefeeder remains safe to operate. Be sure all safety covers have been installed before returning the prefeeder to normal operations. Safety covers on the prefeeder include any covers installed by your direct supplier, as well as standard, permanent guarding.

### Operating & Maintenance: Do's & Don'ts



**Don't Install the Prefeeder Near Flammable Gas, Vapor or Dust.** You must install additional approved explosion-proof or dust-ignition-proof enclosures if installation occurs under these conditions. Without such additional enclosures, normal sparking of the brushes inside the (DC) motor could ignite flammable gas, vapor, or dust.

**Do Not Overfill The Hopper.** Overfilling the hopper can cause parts to jam inside the hopper, and may damage the prefeeder belt and associated guides.

**Do Use the Same or Identical Mounting Screws if Replacing the Motor.** If longer mounting screws are used, they may come into contact with parts of the motor that conduct electricity.

**Do Not Speed Up Prefeeder.** Never raise the prefeeder speed to increase the delivery rate. Too many parts in the feeder may prevent it from operating properly.

**Avoid Solvents.** Do not use solvents for cleaning unless specified, as they may damage surfaces, causing jams or lowered output rates.

# Installation & Start-Up

## 3

### If the Prefeeder is Already Set Up

If you've bought a prefeeder as part of a Shibuya Hoppmann feeder system, then your direct supplier will have performed all the procedures in this chapter. However, you will still need to:

- Position Your Prefeeder.** Follow the equipment layout drawing provided by your direct supplier.
- Connect Electrical Wiring.** Follow as-built electrical diagrams provided by your direct supplier.
- Install & Test the Rest of the System.** Installation is complete.



**Note:** If the prefeeder is drop-shipped to your location, follow the procedures in this chapter to finish setting up the prefeeder.

### Unpacking and Inspection

**Step 1 – Inspect and Unpack the Crate.** Remove packing materials from sensors, covers, and moving parts. Make a visual check to be sure parts have not come loose during shipping. If you find any concealed damage, call the shipping carrier and your direct supplier immediately. **Do not attempt to fix the problem yourself unless told to do so by your direct supplier.**



**Step 2 – Record Serial Number of Prefeeder.** If you have not already done so, record the prefeeder's model and serial number on the front of this manual. This information is helpful when ordering replacement parts or service.

<b>Shibuya Hoppmann™</b>			
SERIAL #	000XXX	DATE	MM/DD
MODEL #	LB-03/06 PREFEEDER, DC MOTOR		
INVENTORY #	PER1PR,XXXX		
PROJECT NUMBER	PRJXXXXXX		
www.shibuyahoppmann.com • (800) 368-3582			

Figure 3-1. Sample Serial Plate

## Physical Setup

### LB-01 Prefeeder Only

**Step 1 – Reassemble the Prefeeder.** The mounted gearmotor and delivery chute which were detached for shipping must be reinstalled. To reinstall, use the hardware and directions provided with your prefeeder.

**Step 2 – Position the Prefeeder.** Place the prefeeder as shown on the equipment layout drawing provided by your direct supplier.

**Step 3 – Position the Feeder.** If you are using a Hoppmann™ Centrifugal Feeder, position the prefeeder so discharged product falls halfway between the center and the inside edge of the bowl (opposite from the point where product loads onto the rim for qualification—refer to Centrifugal Feeder manual). Avoid positioning the prefeeder in a way that allows product to bounce up onto the rim of the bowl and disturb parts that are already oriented. If you are not using a Hoppmann™ Centrifugal Feeder, follow the equipment layout drawing provided by your direct supplier, or the prefeeder may not operate correctly. Level the unit by adjusting the leveling feet and tighten the locknuts.

**Step 4 – Connect Power and Air.** Connect the prefeeder to power and compressed air (if applicable). Do not change the main air regulator: it should already be correctly set when you receive your prefeeder.



## Installing Hopper Extensions

Hopper extensions can be added to the LB-03 (to create a 6 cubic foot hopper). When installing hopper extensions, be sure that the prefeeder is powered off, and that the electrical system is tagged out. Use the hardware provided for installation of the hopper.

**Step 1 – Align New Hopper Extension.** The hopper extension is a welded, one-piece unit that fits atop the existing hopper. Align the extension, using the pre-drilled holes in the extension and the existing hopper as guides. Once aligned, use the hardware provided with the extension to secure it into place atop the base hopper.

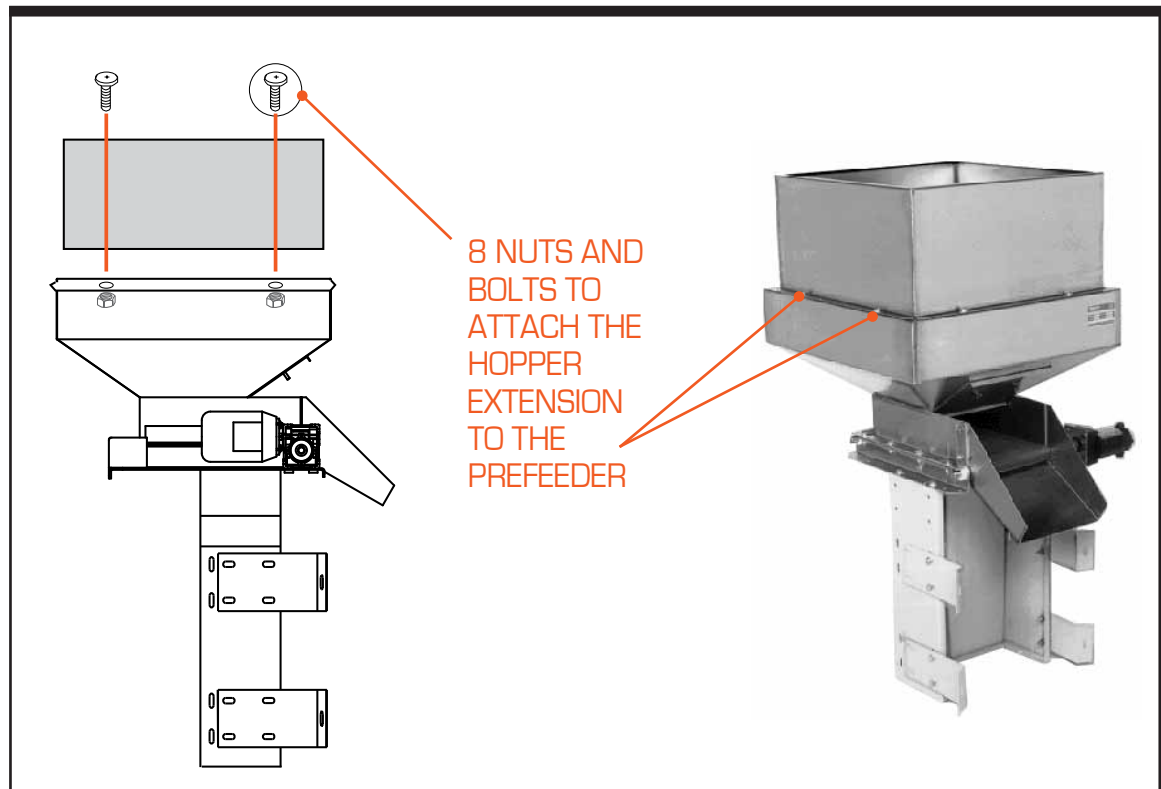

Figure 3-2. Hopper Extension for the LB-03

## Level Sensor

The most common method of controlling the prefeeder is with a level sensing device (sold separately). This device monitors the down stream equipment and tells the prefeeder when to supply product by activating the motor on the prefeeder for a duration of time. The sensor keeps the level of product, from the prefeeder to the equipment, relatively constant by controlling the amount of product metered into the receiving equipment. For further information contact Shibuya Hoppmann Corporation, or your direct supplier.

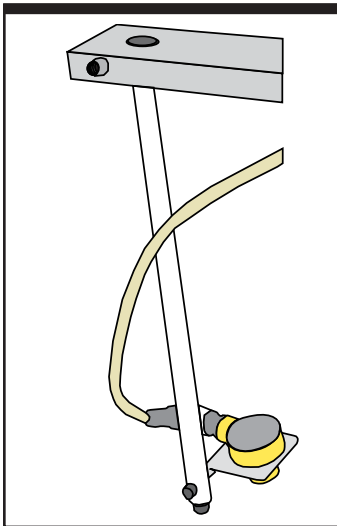

Figure 3-3. Optical Bowl Level Sensor (Optional)



Figure 3-4. Mechanical Bowl Level Sensor (Optional)

## Establishing the Correct Prefeeder Speed

To establish the correct prefeeder speed, turn the prefeeder's speed control to one-quarter (1/4) of its maximum setting. Once product begins to exit the centrifugal feeder or other equipment determine the output of your prefeeder. To obtain a valid rate, count product for at least one minute.

# Preventive Maintenance

## 4

### Belt/Drive Assembly

The main components of the belt/drive pulley assembly are a gear motor, timing belt, a pair of pulley shafts and a drive coupling. Refer to Figure 4-1 for part description and the assembly orientation.

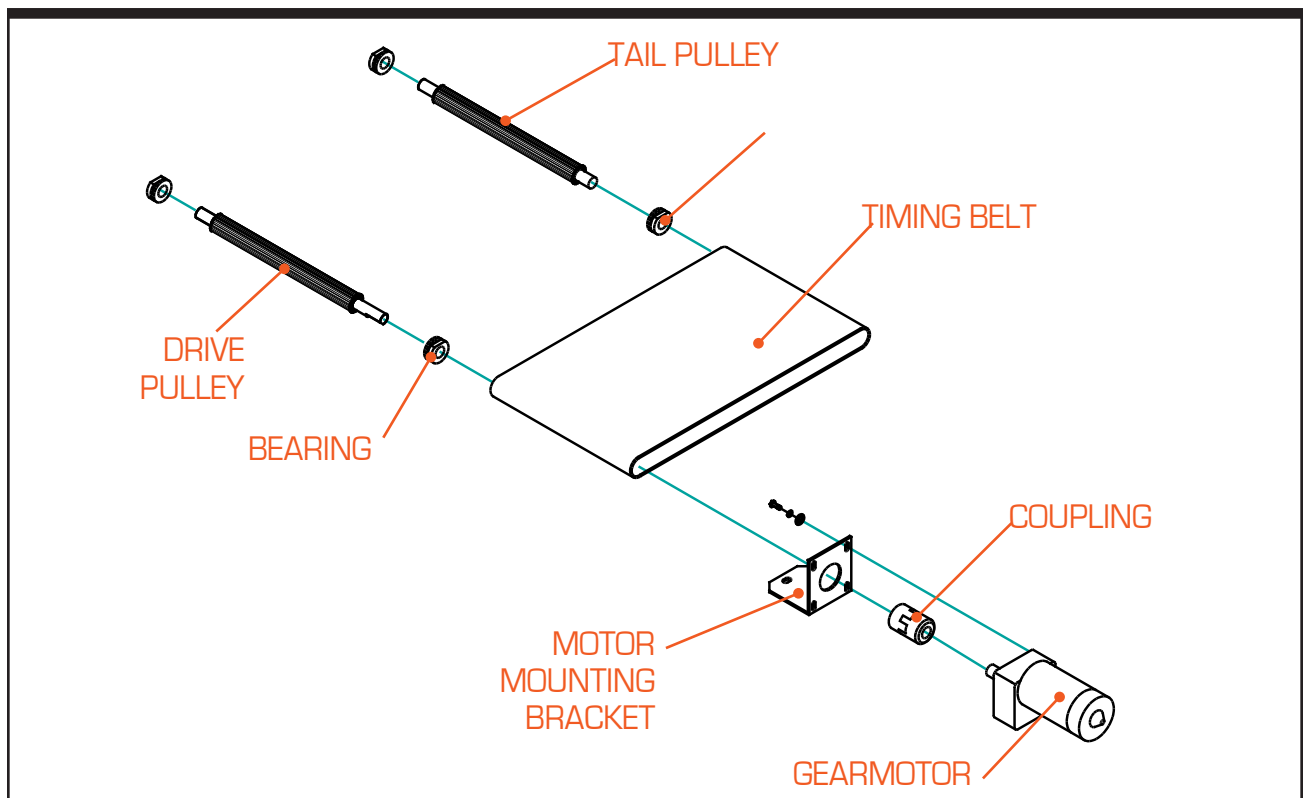

Figure 4-1. Belt/Drive Assembly [DC Motor Shown for Clarification]

### Replacing the Belt

Follow the steps below when replacing the belt on your prefeeder.

**Step 1 – Disconnect the Power.** Make sure the electrical power is turned off in a way which accidental reactivation is prevented.

**Step 2 – Remove the Gear Motor.** First remove the gear motor with the wiring attached by removing the four bolts that connect the motor to the mounting bracket and prefeeder.

**Step 3 – Detach the Belt Assembly.** Remove the prefeeder from the equipment by separating the belt assembly and the hopper from the mounted equipment.

**Step 4 – Remove the Hopper From the Belt Assembly.** Once the prefeeder has been disconnected from the equipment, remove the hopper mounting screws. This will separate the hopper from the belt assembly and give technician access to the belt.

**Step 5 – Remove and Replace the Belt.** Remove the old belt from the frame of the prefeeder. Place the new belt on the frame. Make sure the flat end of the drive pulley is aligned with the coupling and the set screw.

**Step 6 – Replace the Hopper.** Once the belt is in the correct position, tighten any loose screws (no tracking adjustment of the belt is necessary). Replace the hopper and secure it to the prefeeder.

**Step 7 – Remount the Prefeeder.** After the prefeeder is reassembled, remount the prefeeder to the equipment.

**Step 8 – Reinstall the Gear Motor.** After mounting the prefeeder reinstall the gear motor.

**Step 8 – Reconnect Power.** Reconnect power to the system and add parts to the hopper and check the operation of the prefeeder.

## Gear Motor Maintenance



**Disconnect power before performing the following maintenance procedures!**

Check for wear on the gear motor brushes by removing and inspecting each brush. If the brush is worn, replace with a new brush. Make sure to replace the brushes in the same axial position.



**Note: Prefeeders are equipped with acetal plastic bearings which do not require any maintenance and should not be lubricated.**

## **Routine Cleaning**

When necessary, clean the belt surface with a cloth dampened with water, or you can use a mild household cleaner. Wipe off damp surfaces with a dry, clean cloth.

The entire prefeeder can be wiped down with a clean cloth, and stainless steel cleaner may be used if needed. Do not use any type of abrasive cleanser on the equipment.

## Notes

---

# Replacement Parts

## 5

### Replacement Parts

Replacement parts lists for the Hoppmann prefeeders are listed on the following pages. When ordering replacement parts, please reference the model name and number of your prefeeder located on the serial plate (see Figure 5-1). This helps in making sure you receive the correct replacement parts.

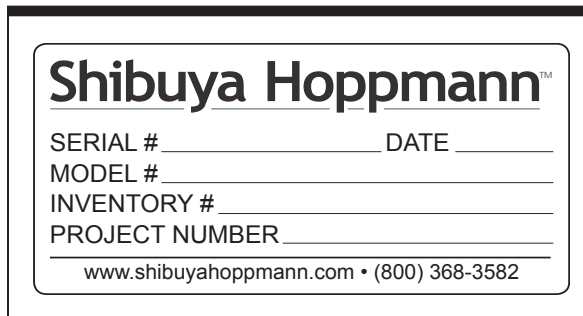

The image shows a rectangular serial plate with a black border. At the top, it reads "Shibuya Hoppmann™". Below this, there are four lines of text, each followed by a horizontal line for a value: "SERIAL # \_\_\_\_\_ DATE \_\_\_\_\_", "MODEL # \_\_\_\_\_", "INVENTORY # \_\_\_\_\_", and "PROJECT NUMBER \_\_\_\_\_". At the bottom of the plate, the website "www.shibuyahoppmann.com" and the phone number "(800) 368-3582" are printed.

Figure 5-1. Sample Serial Plate

If you received a customized Shibuya Hoppmann system, please refer to your system's Operation Manual when ordering spares, as your prefeeder may have been altered.

Having the serial number in addition to the part number you wish to order will help us to accurately assist you in getting the correct parts. You may order your prefeeder's spare parts directly from Shibuya Hoppmann by email, phone or fax (see the contact information listed below).

Shibuya Hoppmann Spares and Service Department

- ➔ **Email:** Spares@Hoppmann.com
- ➔ **Phone:** 434.929.4746 (1.800.543.0915)
- ➔ **Fax:** 434.929.4959
- ➔ **Mail:** Shibuya Hoppmann Corporation  
Attn: Spares Department  
291 Dillard Road  
Madison Heights, VA 24572 USA  
www.ShibuyaHoppmann.com

---

**Notes:** Occasional product serial numbers will be preceded by a "V" or "C", which indicates the equipment has been customized for you specifically. When calling for parts, be sure to indicate if your equipment has this configuration (example: VLB0306XXDSA).

Critical LB-01 Replacement Parts		
Part Number	Description	Qty.
MOTR013021	1/30hp Gear Motor, 90VDC, 62:1, 21 RPM	1
MOTRAC12HP	.12hp Motor, 208-230/460	1
NMRV30M080	Speed Reducer, 80:1, M63B14	1
BELT200L50	LB-01 Standard Belt *	1
BELT200F50	LB-01 Food Grade Belt *	1

Recommended LB-01 Replacement Parts		
Part Number	Description	Qty.
COUPHALF04	Coupling Half, 5/16" B L050	1
COUPHALF05	Coupling Half, 5/8" B L050	2
COUPSPID01	Coupling Spider, L050	1
COUPHALF07	Coupling Half, 25mm L095	2
COUPSPID03	Coupling Spider, SOX	1
LB30008	Bearing	4
LB10100	Drive Pulley Kanban	1
LB10200	Tail Pulley Kanban	1
LB01T00016	Chute, LB-01	

BLUE = DC MOTOR DRIVE
RED = AC MOTOR DRIVE

\*Either a standard belt, or food grade belt, was used on your system. Make sure you are replacing the correct belt when ordering.



### Critical LB-03/06 Replacement Parts

Part Number	Description	Qty.
MOTR013021	1/30hp Gear Motor, 90VDC, 62:1, 21 RPM	1
MOTRAC12HP	.12hp Motor, 208-230/460	1
NMRV30M080	Speed Reducer, 80:1	1
BELT352L99	LB3 Standard Belt *	1
BELT352F99	LB3 Food Grade Belt, Tan *	1

### Recommended LB-03/06 Replacement Parts

Part Number	Description	Qty.
COUPHALF04	Coupling Half, 5/16" B L050	1
COUPHALF05	Coupling Half, 5/8" B L050	2
COUPSPID01	Coupling Spider, L050	1
COUPHALF19	Coupling Half, L050 x 14mm	1
COUPHALF05	Coupling Half, 5/8" B L050	2
LB30008	Bearing	4
LB30200	Drive Pulley Assembly Kanban	1
LB30300	Tail Pulley Assembly Kanban	1
LB30005	Channel Belt Assembly	1
LB30100	Hopper Assembly	1

BLUE = DC MOTOR DRIVE
-----------------------

RED = AC MOTOR DRIVE
----------------------

\*Either a standard belt, or food grade belt, was used on your system. Make sure you are replacing the correct belt when ordering.

## Notes

---

# Warranty

## 6

### Warranty

Shibuya Hoppmann Corporation warrants that each item of its own manufacture delivered hereunder shall, at the time of delivery and for a period of twelve (12) months thereafter, be free from defects in materials or workmanship; and if any such item shall prove to be defective in material or workmanship under normal intended usage and maintenance during the warranty period, upon examination by Shibuya Hoppmann Corporation, then Shibuya Hoppmann Corporation shall repair or replace, at its sole option, such defective item at its own expense; provided, however, that the owner shall be required to ship such defective item, freight prepaid, to Shibuya Hoppmann Corporation's plant in Madison Heights, Virginia. The warranty on components not manufactured by Shibuya Hoppmann Corporation, but a part of the feeder, is limited to the warranty provided by the original manufacturer of said components to the extent, and only to the extent, that such original manufacturer actually honors such warranty.

ALL WARRANTIES HEREUNDER ARE EXPRESSLY LIMITED TO THE REPAIR OR REPLACEMENT OF DEFECTIVE ITEMS AS SET FORTH HEREIN, AND IN NO EVENT SHALL SHIBUYA HOPPMANN CORPORATION BE LIABLE FOR SPECIAL, INCIDENTAL OR CONSEQUENTIAL DAMAGES BY REASON OF ANY BREACH OF WARRANTY OR DEFECT IN MATERIAL OR WORKMANSHIP. SHIBUYA HOPPMANN CORPORATION SHALL NOT BE RESPONSIBLE FOR REPAIR OR REPLACEMENT OF ITEMS WHICH HAVE BEEN SUBJECTED TO NEGLIGENCE, ACCIDENT OR IMPROPER USE, OR WHICH HAVE BEEN ALTERED BY OTHER THAN AUTHORIZED SHIBUYA HOPPMANN CORPORATION PERSONNEL.

THIS WARRANTY IS IN LIEU OF OTHER WARRANTIES, EXPRESS OR IMPLIED. ALL IMPLIED WARRANTIES, INCLUDING BUT NOT LIMITED TO THE IMPLIED WARRANTIES OF MERCHANTABILITY AND FITNESS FOR A PARTICULAR PURPOSE, ARE HEREBY EXCLUDED.

## Shibuya Hoppmann offers a wide selection of products:

- ➔ Hoppmann Centrifugal Feeders™
- ➔ Prefeeder
- ➔ Continuous Motion Assembly Turrets
- ➔ Placement Systems
- ➔ Fillers and Cappers
- ➔ Conveyors
- ➔ Product Handling Equipment
- ➔ Aseptic Filling Systems
- ➔ Labelers
- ➔ Decontamination Equipment
- ➔ Intermittent Motion Assembly Systems
- ➔ Complete Integrated Product Lines

### Headquarters

7849 Coppermine Drive  
Manassas, VA  
20109  
540.829.2564 t  
800.368.3582 t  
540.829.1726 f

### Sales

1445 Brookville Way  
Suite F  
Indianapolis, IN 46239  
317.322.0754 t  
800.368.3582 t  
317.322.0794 f

### Manufacturing

291 Dillard Road  
Madison Heights, VA  
24572  
434.929.4746 t  
800.543.0915 t  
434.929.4959 f