



**Product Overview:**

Shibuya Hoppmann's standard FS-60 scallop feeder is designed to feed and orient bottles and other cylindrical parts with the use of urethane scallops. Parts are radially oriented and gently qualified in the scallop pockets by means of sweeps, wipers, pneumatic and/or electric devices depending on specific product characteristics. Oriented parts are discharged and carried away by various downstream in-line devices.

|               |            |
|---------------|------------|
| Part Number   | FS601RLASA |
| Motor Style   | AC         |
| Motor Voltage | 230/460V   |
| Horsepower    | 1hp        |

**Standard Features:**

- All stainless steel exterior construction
- FDA approved ABS vacuum formed disc
- Teflon hard-coated finished aluminum bowl predrilled for scallop mounting
- Air clutch
- Hinged polycarbonate cover with safety interlocks
- Backup Ring

**Available Options:**

- Washdown motor(s)
- Urethane scallop kit
- NEMA 1 encased controller

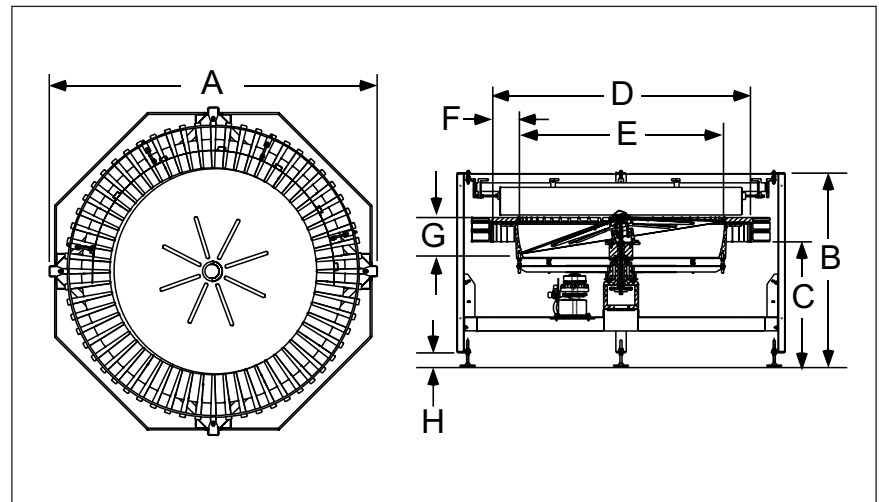

|   |            |
|---|------------|
| <b>Accessories:</b>   |            |
| FS Series Scallop Kit   | FS60SCALXX |
| (includes segment plates and one of the following number of scallops: 36, 48, 54, 60 or 72) |            |

| Product Specifications |                       | ANSI       | Metric      |
|------------------------|-----------------------|------------|-------------|
| A                      | Outside Diameter      | 93"        | 2362mm      |
| B                      | Frame Height          | 47" ± 1.5" | 1194 ± 40mm |
| C                      | Discharge Height      | 36" ± 2"   | 914 ± 51mm  |
| D                      | Bowl Outside Diameter | 70"        | 1778mm      |
| E                      | Bowl Inside Diameter  | 60"        | 1524mm      |
| F                      | Rim Width             | 5"         | 127mm       |
| G                      | Bowl Depth            | 9.13"      | 232mm       |
| H                      | Level Foot Adjustment | 5" ± 2.5"  | 127 ± 64mm  |

**Headquarters**  
13129 Airpark Dr.  
Suite 120  
Elkwood, VA 22718  
540.829.2564 t  
800.368.3582 t  
540.829.1726 f

**Sales Office**  
1445 Brookville Way  
Suite F  
Indianapolis, IN 46239  
317.322.0754 t  
800.368.3582 t  
317.322.0794 f

**Manufacturing Office**  
291 Dillard Road  
Madison Heights, VA  
24572  
434.929.4746 t  
800.543.0915 t  
434.929.4959 f

[www.ShibuyaHoppmann.com](http://www.ShibuyaHoppmann.com) | [sales@ShibuyaHoppmann.com](mailto:sales@ShibuyaHoppmann.com)

Shibuya Hoppmann Corporation strives to improve its products and reserves the right to change or discontinue specifications & designs shown in this brochure without notice and without incurring obligation. Revised: 12/11.