



### Product Overview:

The Shibuya Hoppmann ET-02 Elevating Table Top Prefeeder is designed to handle a variety of small sized, light weight parts with both an adjustable base and head chute to accommodate small product loading and delivery variances. The concept is based on the standard sized elevating prefeeders but has a more compact footprint and is designed to be mounted on top of an existing support table.

Part Number	ET0206XASA
Motor Style	AC Motor
Motor Voltage	220/380V
Horsepower	1/5hp
Total Equipment Weight	185 lbs (83.9 kg)
Hopper Capacity (ET-02/03/04)	2 ft <sup>3</sup> / 3 ft <sup>3</sup> / 4 ft <sup>3</sup> (56 / 85 / 113 liters)

### Standard Features:

- All stainless steel construction
- Belt (6" width belt, 4" pitch with 1.5" cleat) FDA/USDA approved white 1-ply solid woven polyester fabric with 1/16" thick white PVC coating and PVC cleats
- Hopper clean out door

### Available Options:

- Safety cover package
- 18", 24", 36" and 54" elevator extensions available
- Hopper extensions
- Optional belt styles and widths, such as: standard cleat for 85° tilt, blue sanitary belt, super cleat belt

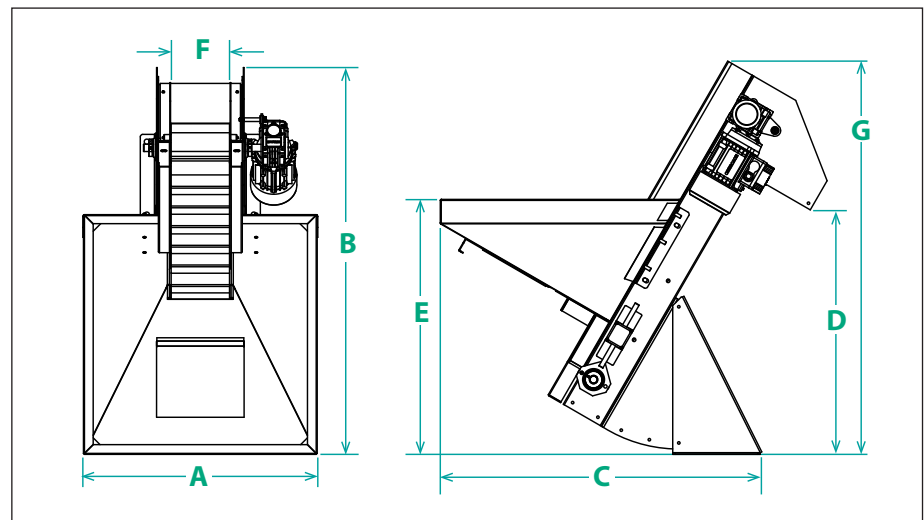

Product Specifications		ANSI	Metric
A	Overall Width	24.03"	610.3mm
B	Overall Length	39.77"	1010.2mm
C	Lower Footprint	32.90"	835.7mm
D	Discharge Height	25.13"	638.3mm
E	Hopper Load Height* (ET-02)	26.23"	667.0mm
E	Hopper Load Height* (ET-03)	28.80"	731.5mm
E	Hopper Load Height* (ET-04)	32.00"	812.8mm
F	Belt Width	6.00"	152.4mm
G	Overall Height	40.43"	1026.9mm

\*Note: These heights are measured from the top of the support table to the top of the hopper.