



Model FT-40/50-RD Centrifugal Feeders

ANSI/Metric Installation & Maintenance Manual

**Refer all servicing to
qualified personnel.**

*This manual is written for qualified
mechanics and electricians
who must install or service the
FT-40-RD or FT-50-RD Feeder.*

**Use this manual for FT-40-RD &
FT-50-RD ANSI or Metric, cold
rolled or stainless steel model
feeders manufactured after 10/96.**



*Please copy this information
from the FT-40-RD or FT-50-RD
Feeder's serial plate.*

Model Number:

Serial Number/Date:

Inventory Number (Check One):

- | | | | |
|-------------------------------------|-------------------------------------|-------------------------------------|-------------------------------------|
| <input type="checkbox"/> FT401RLDCA | <input type="checkbox"/> FT401RLDCM | <input type="checkbox"/> FT501RLDCA | <input type="checkbox"/> FT501RLDCM |
| <input type="checkbox"/> FT401RLDSA | <input type="checkbox"/> FT401RLDSM | <input type="checkbox"/> FT501RLDSA | <input type="checkbox"/> FT501RLDSM |
| <input type="checkbox"/> FT401RLACA | <input type="checkbox"/> FT401RLACM | <input type="checkbox"/> FT501RLACA | <input type="checkbox"/> FT501RLACM |
| <input type="checkbox"/> FT401RLASA | <input type="checkbox"/> FT401RLASM | <input type="checkbox"/> FT501RLASA | <input type="checkbox"/> FT501RLASM |
| <input type="checkbox"/> FT402RLDCA | <input type="checkbox"/> FT402RLDCM | <input type="checkbox"/> FT502RLDCA | <input type="checkbox"/> FT502RLDCM |
| <input type="checkbox"/> FT402RLDSA | <input type="checkbox"/> FT402RLDSM | <input type="checkbox"/> FT502RLDSA | <input type="checkbox"/> FT502RLDSM |
| <input type="checkbox"/> FT402RLACA | <input type="checkbox"/> FT402RLACM | <input type="checkbox"/> FT502RLACA | <input type="checkbox"/> FT502RLACM |
| <input type="checkbox"/> FT402RLASA | <input type="checkbox"/> FT402RLASM | <input type="checkbox"/> FT502RLASA | <input type="checkbox"/> FT502RLASM |



Third Edition, Revision 1, All Rights Reserved

Copyright © 2005 by Hoppmann/Shibuya.

13129 Airpark Drive, Suite 120

Elkwood, Virginia 22718

Phone: (540) 829-2564

Toll Free: (800) 368-3582

Fax: (540) 829-1724

www.hoppmann.com • email: publications@hoppmann.com

Quick Start

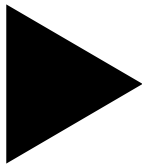

About this Manual

Assumptions

This manual is written for qualified mechanics or electricians who install or service the FT-40-RD or FT-50-RD Centrifugal Feeder. All procedures in this manual should be performed by qualified personnel.

► References in this manual may not apply to your FT-40-RD or FT-50-RD feeder. In some cases, your direct supplier may have modified or replaced some of the standard components of the feeder on which these procedures are based. In such cases, you may need to slightly modify these procedures. If you are unsure which standard components of your FT-40-RD or FT-50-RD feeder (if any) have been changed, consult your direct supplier's documentation.

Models Covered

This manual covers thirty-two models. If you are unsure which model you have, locate the inventory number on the serial plate of the feeder.

<i>Inventory No.</i>	<i>Metric</i>	<i>Inventory No.</i>	<i>ANSI</i>
FT401RLDCA	1 DC Motor	FT401RLDCM	1 DC Motor
FT401RLACA	1 AC Motor	FT401RLACM	1 AC Motor
FT402RLDCA	2 DC Motors	FT402RLDCM	2 DC Motors
FT402RLACA	2 AC Motors	FT402RLACM	2 AC Motors
FT501RLDCA	1 DC Motor	FT501RLDCM	1 DC Motor
FT501RLACA	1 AC Motor	FT501RLACM	1 AC Motor
FT502RLDCA	2 DC Motors	FT502RLDCM	2 DC Motors
FT502RLACA	2 AC Motors	FT502RLACM	2 AC Motors

<i>Inventory No.</i>	<i>ANSI, SS</i>	<i>Inventory No.</i>	<i>Metric, SS</i>
FT401RLDSA	1 DC Motor	FT401RLDSM	1 DC Motor
FT401RLASA	1 AC Motor	FT401RLASM	1 AC Motor
FT402RLDSA	2 DC Motors	FT402RLDSM	2 DC Motors
FT402RLASA	2 AC Motors	FT402RLASM	2 AC Motors
FT501RLDSA	1 DC Motor	FT501RLDSM	1 DC Motor
FT501RLASA	1 AC Motor	FT501RLASM	1 AC Motor
FT502RLASA	2 AC Motor	FT502RLASM	2 AC Motor
FT502RLDSA	2 DC Motor	FT502RLDSM	2 DC Motor

Equipment Improvements & Document Revisions Notice

Shibuya Hoppmann continually improves its products, and reserves the right to change or discontinue specifications and designs shown in this manual without notice and without incurring obligation. Shibuya Hoppmann has made every effort to verify the information contained in this manual, but reserves the right to correct any error at the time of the manual's next revision.

Caution Symbols & Messages

Caution symbols and messages in this manual call attention to hazardous voltages, moving parts and other hazardous conditions.



The exclamation point caution symbol denotes possible personal injury and/or damage to the equipment.



The lightning bolt caution symbol denotes possible personal injury and/or damage to the equipment from electrical hazards.

What to Do First

As-Built Documentation

This manual does not contain as-built documentation. Obtain as-built documentation from your direct supplier. If you purchased your tooled feeder directly from Hoppmann Corporation, you will automatically receive this information in your System Operations Manual.

Tools You Will Need

The FT-40/50-RD feeders are offered in both ANSI and metric versions. For maximum compatibility, ANSI units are classified as "soft ANSI" construction, meaning that metric threads and hardware are used throughout. Both metric and ANSI units require metric tools for repair or adjustment. If your direct supplier tooled your feeder with ANSI hardware, you will need ANSI tools as well.



Any part of the feeder that touches your product has been precision tooled to specifically match your product. Do not move tooling or change feeder settings except as directed in this manual, your System Operations Manual or by your direct supplier. Otherwise, you may void your warranty and negatively affect the performance of your feeder.

Table of Contents

	Page	Chapter
Quick Start	2	About this Manual
	3	What to Do First
Feeder Description & Specifications	7	Overview of the FT-40-RD & FT-50-RD <i>Figures:</i>
	6	Figure 1-1. FT-40/50-RD Feeder (Dual Drive) Overall Exploded View
	8	Table 1-1. FT-40-RD Feeder Specifications (Single Drive)
	9	Figure 1-2. FT-40-RD Feeder Specifications (Single Drive)
	10	Table 1-2. FT-40-RD Feeder Specifications (Dual Drive)
	11	Figure 1-3. FT-40-RD Feeder Specifications (Dual Drive)
	12	Table 1-3. FT-50-RD Feeder Specifications (Single Drive)
	13	Figure 1-4. FT-50-RD Feeder Specifications (Single Drive)
	14	Table 1-4. FT-50-RD Feeder Specifications (Dual Drive)
	15	Figure 1-5. FT-50-RD Feeder Specifications (Dual Drive)
Safety Precautions	17	Safety Precautions
	17	Operating & Maintenance: Do's & Don'ts
Installation & Startup	19	Unpacking, Inspection & Registration
	19	Physical Setup
	20	Starting the Feeder for the First Time
	21	How to Set Proper Bowl Speed
	22	Running Product for the First Time
	22	General Tips
		<i>Figures:</i>
	21	Figure 3-1. Measuring & Changing Bowl Speed
	23	Figure 3-2. FT-40/50-RD AC Metric Wiring Dia. (Single Drive)
	24	Figure 3-3. FT-40/50-RD AC Metric Wiring Dia. (Dual Drive)
25	Figure 3-4. FT-40/50-RD DC ANSI Wiring Dia. (Dual Drive)	
26	Figure 3-5. FT-40-RD DC ANSI Wiring Dia. (Single Drive)	
27	Figure 3-6. FT-50-RD DC ANSI Wiring Dia. (Single Drive)	
28	Figure 3-7. FT-40/50-RD DC Metric Wiring Dia. (Single Drive)	
29	Figure 3-8. FT-40/50-RD AC ANSI Wiring Dia. (Single Drive)	
30	Figure 3-9. FT-40/50-RD DC Metric Wiring Dia. (Dual Drive)	
31	Figure 3-10. FT-40-RD AC ANSI Wiring Dia. (Dual Drive)	

1

2

3

	Page	Chapter
Preventive Maintenance	33	General Cleaning
	33	Change Gear Oil in ANSI Speed Reducer
	35	Idler Assembly Maintenance
	35	Chains and Sprockets
	35	Inspect Chain Tension
	37	Inspect/Replace Motor Brushes
		Figures:
	33	Figure 4-1. Gear Oil Fill Level
	34	Figure 4-2. Recommended Gear Oil
	35	Figure 4-3. Assembled View (Idler)
	36	Figure 4-4. FT-40/50-RD Drive Train (DC Motor)
	37	Figure 4-5. Motor Brushes (DC Motor)
	Repair & Troubleshooting	39
41		Idler Assembly Component Replacement
41		Replacing or Refinishing a Damaged Bowl
42		How to Set Bowl Runout
43		ANSI Speed Reducer Replacement
45		Metric Speed Reducer Replacement
47		Major Bearing Replacement
49		If Product Jam: General Tips
50		Troubleshooting Charts
		Figures:
40		Figure 5-1. Torque Limiter Assembly
41		Figure 5-2. Idler Assembly
41		Figure 5-3. Bowl Connection
44	Figure 5-4. FT-40/50-RD Speed Reducer and Motor	
47	Figure 5-5. FT-40/50-RD Spindle Assembly	
48	Figure 5-6. FT-40/50-RD Spindle Assembly	
51	Figure 5-7. FT-40/50-RD Feeder Troubleshooting	
52	Figure 5-8. FT-40/50-RD Feeder Troubleshooting	
Replacement Parts	53	Notice to Hoppmann Customers
	54	Notice to Dealer & OEM Customers
	55	Warranty
	56	Scheduled Mechanical Maintenance Log
		Figures:
	53	Figure 6-1. Serial Plate Layouts

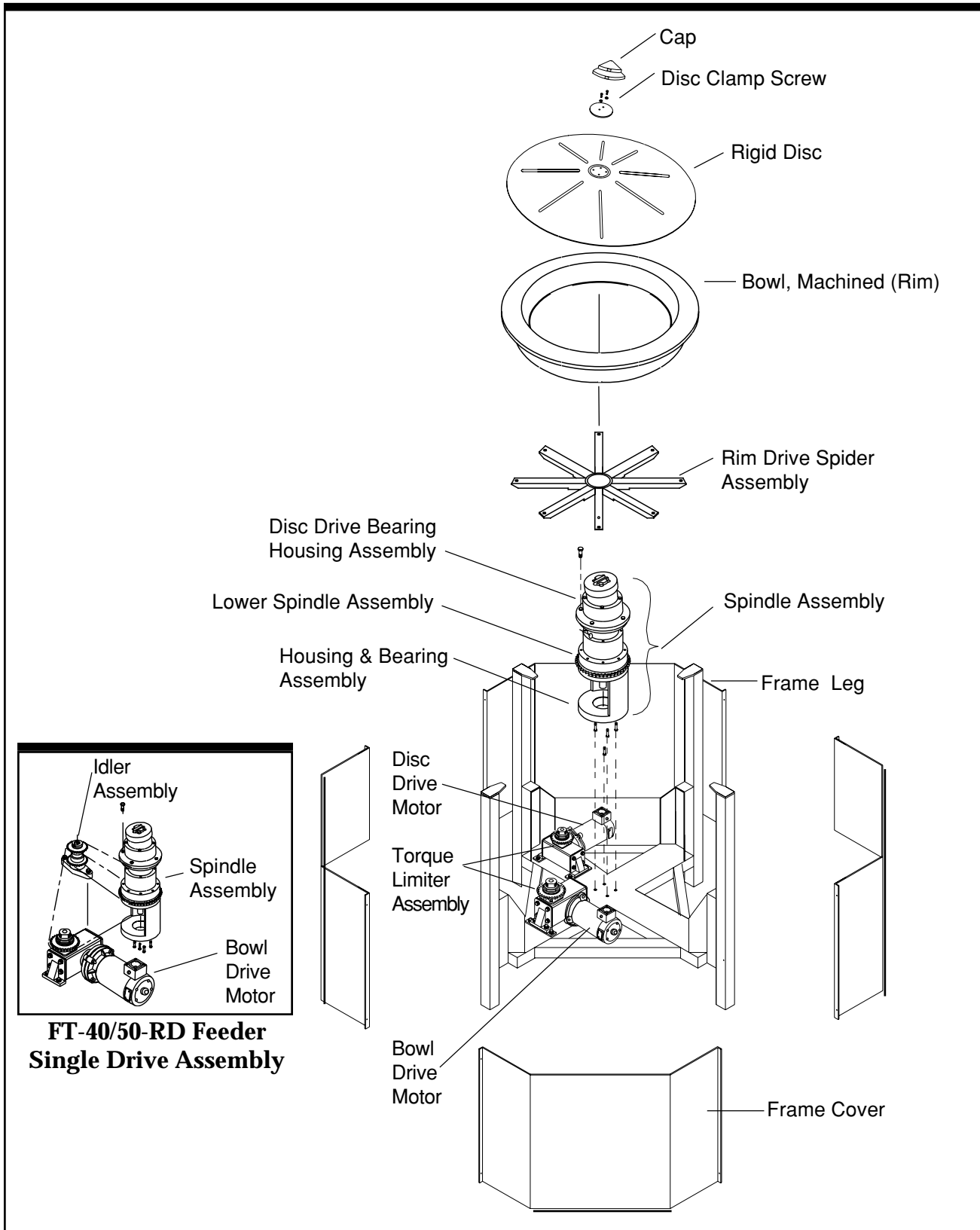

FT-40/50-RD Feeder Single Drive Assembly

Figure 1-1. FT-40/50-RD Feeder (Dual Drive) : Overall Exploded View

Feeder Description & Specifications

1

The FT-40/50-RD Feeder: An Overview

Function The FT-40/50-RD feeders unscrambles, feeds and orients parts. Simply put, it delivers aligned parts. Every FT-40/50-RD feeder operates in the same basic way.

Operation **Step 1—The FT-40/50-RD Feeder Accepts Your Parts.** The FT-40/50-RD feeders accept parts from a separate bulk supply hopper or prefeeder. Parts drop randomly, a few at a time, onto a rigid disc. Unlike vibratory feeders, the FT-40/50-RD feeders run best when parts are not emptied in bulk directly onto the rigid disc, but instead, when parts are carefully metered into the feeder bowl, a few parts at a time. The FT-40/50-RD feeders deliver parts almost immediately. Compared to vibratory feeders, parts simply do not have time to get scuffed up.

Step 2—The FT-40/50-RD Feeder Loads and Qualifies Your Parts. After dropping onto the rigid disc, parts load quickly onto the rim of a rotating bowl.

▶ The rim moves the parts past mechanical, pneumatic and/or optical qualifiers which reject parts that do not line up the same way. Improperly oriented parts are returned to the bowl and recirculated.

▶ Any part of the FT-40/50-RD feeder that touches your parts has been precision tooled to specifically match your parts, and should be left alone unless absolutely necessary. ***Do not move tooling or change any settings on the FT-40-RD or FT-50-RD feeder except as described in this manual, or you may void your warranty and negatively affect the performance of your FT-40-RD or FT-50-RD Feeder.***



Step 3—The FT-40/50-RD Feeder Delivers Your Parts. Finally, parts move off the rim and out of the FT-40-RD or FT-50-RD feeder, in the proper orientation, in a rapidly moving and randomly spaced stream.

Output Feed Rate The FT-40/50-RD feeder typically handles parts at various output rates depending on your particular part's characteristics and your desired production speed will affect the output rate.

Bowl The standard bowl on the FT-40/50-RD feeders are cast aluminum and are machinable.

FT-40-RD Single Drive Specifications

Specifications - FT-40-RD	ANSI	Metric
Electrical Specifications		
Motor Size	1/2 HP	.37 KW
Motor Frame Size	NEMA 56 C	IEC 71D
Supply Voltage	Refer to Chapter 3 Wiring Diagrams	
Motor Voltage	Refer to Chapter 3 Wiring Diagrams	
Power Usage	6 amps	3 amps
Dimensional Specifications		
A. Outer Wall Diameter	57.50"	1,460.0 mm
B. Overall Height	42.88" ± 1.5"	1089.2 mm ± 25
C. Discharge Height	31.88" ± 1.5"	809.8 mm ± 25
D. Bowl Outer Diameter	44.00"	1117.6 mm
E. Bowl Inner Diameter	36.25"	920.8 mm
F. Rim Width	3.88"	98.4 mm
G. Bowl Depth	5.42"	137.5 mm
H. Leveling Feet Height	4.61"	117.1 mm
Performance Specifications		
Maximum Bowl Linear Speed (@Rim ID)	255 feet/minute	78 meters/minute
Vertical Bowl Runout (Max.)	0.020"	0.50 mm
Vertical Disc Runout (Max.)	0.100"	2.50 mm



Your direct supplier may have changed some of these specifications during tooling to better match your application's requirements.

Table 1-1. FT-40-RD Single Drive Feeder Specifications

FT-40-RD Single Drive Specifications

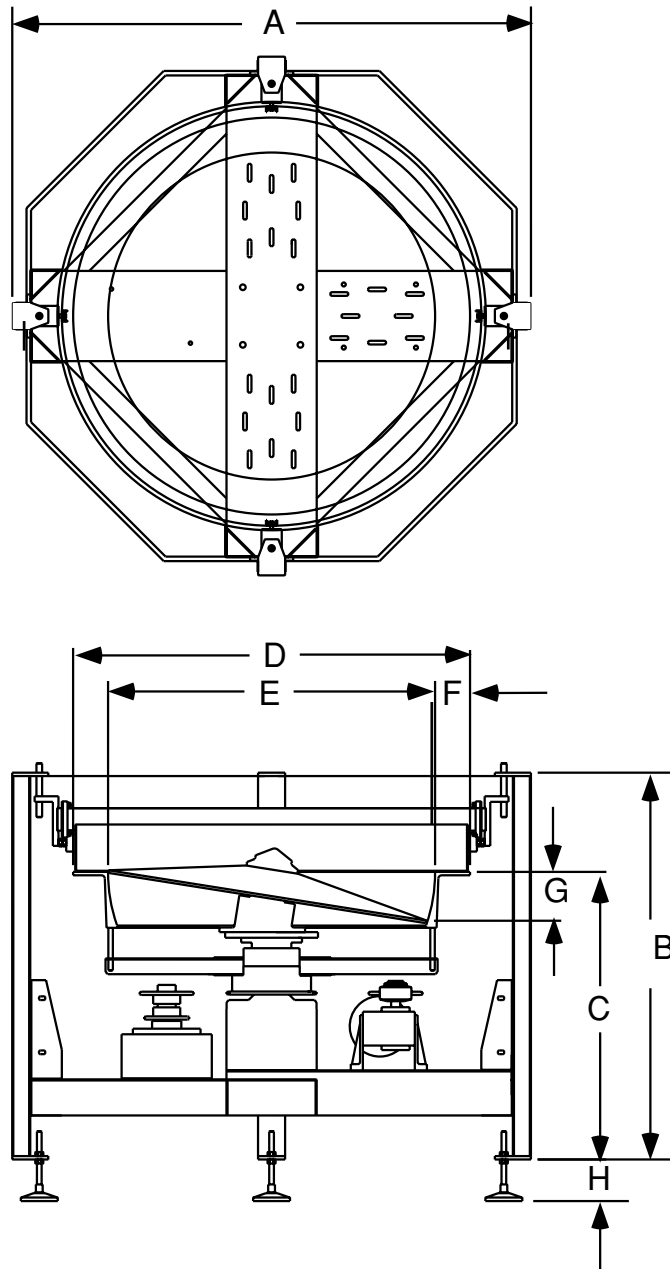

Your direct supplier may have changed some of these specifications during tooling to better match your application's requirements.

Figure 1-2. FT-40-RD Single Drive Feeder Specifications

FT-40-RD Dual Drive Specifications

Specifications - FT-40-RD	ANSI	Metric
Electrical Specifications		
Motor Size - Bowl Drive Motor	1/2 HP	.37 KW
Motor Size - Disc Drive Motor	1/2 HP	.37 KW
Motor Frame Size	NEMA 56 C	IEC 71D
Supply Voltage	Refer to Chapter 3 Wiring Diagrams	
Motor Voltage	Refer to Chapter 3 Wiring Diagrams	
Power Usage	6 amps	3 amps
Dimensional Specifications		
A. Outer Wall Diameter	57.50"	1,460.0 mm
B. Overall Height	42.88" ± 1.5"	1089.2 mm ± 25
C. Discharge Height	31.88" ± 1.5"	809.8 mm ± 25
D. Bowl Outer Diameter	44.00"	1117.6 mm
E. Bowl Inner Diameter	36.25"	920.8 mm
F. Rim Width	3.88"	98.4 mm
G. Bowl Depth	5.42"	137.5 mm
H. Leveling Feet Height	4.61"	117.1 mm
Performance Specifications		
Maximum Bowl Linear Speed (@Rim ID)	255 feet/minute	78 meters/minute
Vertical Bowl Runout (Max.)	0.020"	0.50 mm
Vertical Disc Runout (Max.)	0.100"	2.50 mm



Your direct supplier may have changed some of these specifications during tooling to better match your application's requirements.

Table 1-2. FT-40-RD Dual Drive Feeder Specifications

FT-40-RD Dual Drive Specifications

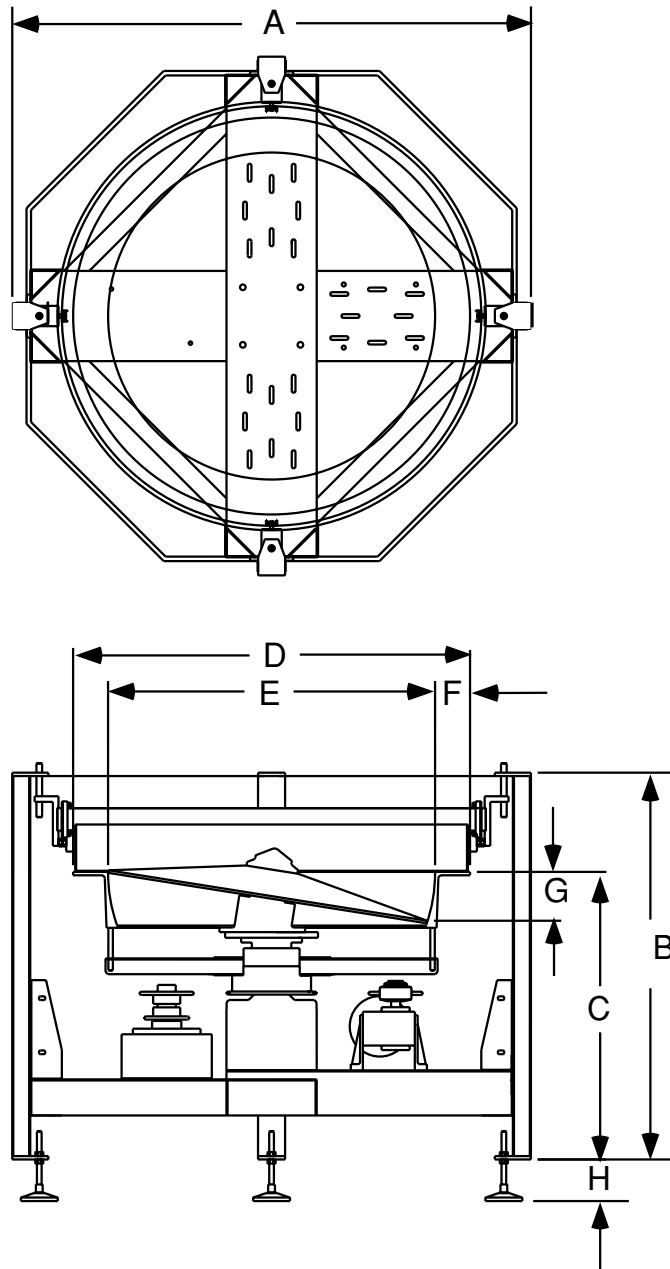

Your direct supplier may have changed some of these specifications during tooling to better match your application's requirements.

Figure 1-3. FT-40-RD Dual Drive Feeder Specifications

FT-50-RD Single Drive Specifications

Specifications - FT-50-RD	ANSI	Metric
Electrical Specifications		
Motor Size	³ / ₄ H.P.	.55KW
Motor Frame Size	NEMA 56C	IEC 71D
Supply Voltage	Refer to Chapter 3 Wiring Diagrams	
Motor Voltage	Refer to Chapter 3 Wiring Diagrams	
Power Usage	8 amps	3 amps
Dimensional Specifications		
A. Outer Wall Diameter	71.00"	1727 mm
B. Overall Height	44.00" ± 2	1232 mm ± 50
C. Discharge Height	32.45" ± 2	824 mm ± 50
D. Bowl Outer Diameter	56.00"	1422 mm
E. Bowl Inner Diameter	47.75"	1213 mm
F. Rim Width	4.13"	105 mm
G. Bowl Depth	7.11"	180 mm
H. Leveling Feet Height	4.61"	117 mm
Performance Specifications		
Maximum Bowl Linear Speed (@Rim ID)	400 ft./minute	102 meters/minute
Vertical Bowl Runout (Max.)	.020"	0.50 mm
Vertical Disc Runout (Max.)	.100"	2.50 mm



Your direct supplier may have changed some of these specifications during tooling to better match your application's requirements.

Table 1-3. FT-50-RD Single Drive Feeder Specifications

FT-50-RD Single Drive Specifications

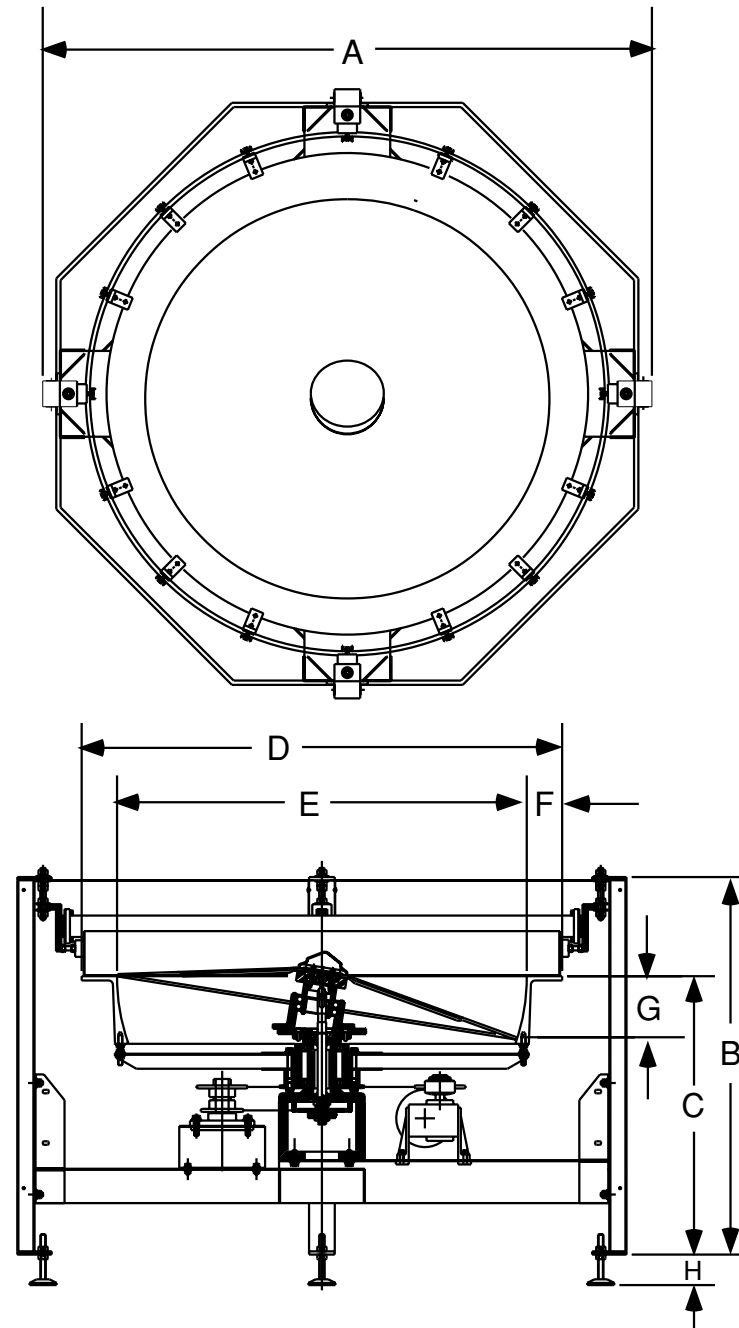

Your direct supplier may have changed some of these specifications during tooling to better match your application's requirements.

Figure 1-4. FT-50-RD Single Drive Feeder Specifications

FT-50-RD Dual Drive Specifications

Specifications - FT-50-RD	ANSI	Metric
Electrical Specifications		
Motor Size - Bowl Drive Motor	3/4 H.P.	.55KW
Motor Size - Disc Drive Motor	1/2 H.P.	.37 KW
Motor Frame Size	NEMA 56C	IEC 71D
Supply Voltage	Refer to Chapter 3 Wiring Diagrams	
Motor Voltage	Refer to Chapter 3 Wiring Diagrams	
Power Usage	8 amps	3 amps
Dimensional Specifications		
A. Outer Wall Diameter	71.00"	1727 mm
B. Overall Height	44.00" ± 2	1232 mm ± 50
C. Discharge Height	32.45" ± 2	824 mm ± 50
D. Bowl Outer Diameter	56.00"	1422 mm
E. Bowl Inner Diameter	47.75"	1213 mm
F. Rim Width	4.13"	105 mm
G. Bowl Depth	7.11"	180 mm
H. Leveling Feet Height	4.61"	117 mm
Performance Specifications		
Maximum Bowl Linear Speed (@Rim ID)	400 ft./minute	102 meters/minute
Vertical Bowl Runout (Max.)	.020"	0.50 mm
Vertical Disc Runout (Max.)	.100"	2.50 mm



Your direct supplier may have changed some of these specifications during tooling to better match your application's requirements.

Table 1-4. FT-50-RD Dual Drive Feeder Specifications

FT-50-RD Dual Drive Specifications

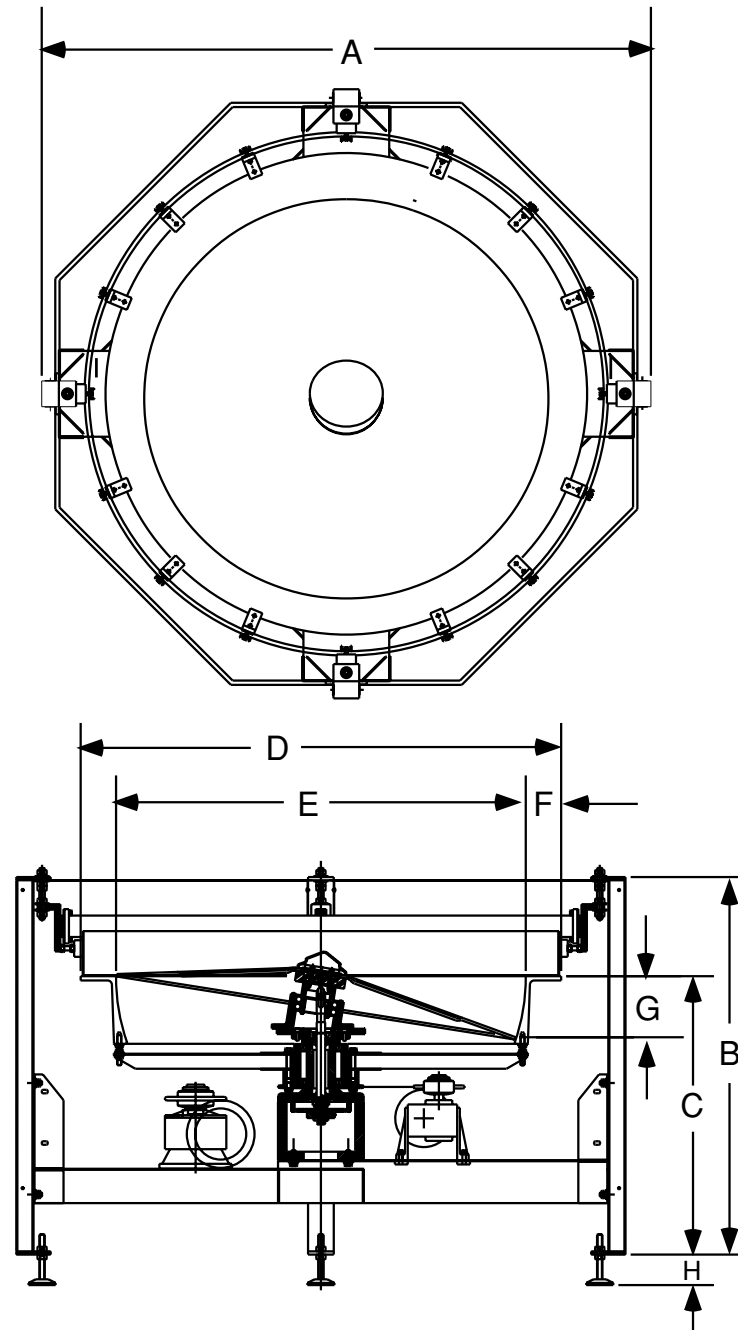

Your direct supplier may have changed some of these specifications during tooling to better match your application's requirements.

Figure 1-5. FT-50-RD Dual Drive Feeder Specifications

Notes

Safety Precautions

2

Safety Precautions



Turn Off Power! Before servicing, make sure you have turned off compressed air and electrical power in a way which prevents accidental reactivation. Padlock and clearly tag the appropriate electrical and pneumatic disconnects. Lockout/tagout procedures are covered in United States Code of Federal Regulation (CFR) Title 29 Part 1910.147, "The Control of Hazardous Energy."



Dress Appropriately! Reduce the risk of injury from moving parts by securing loose sleeves and other clothing. Do not wear loose jewelry or neckties near the feeder. Wear safety glasses or other protective eyewear when servicing the feeder. Never place hands or tools in the feeder when it is operating.



Install Safety Guards! Make sure the feeder remains safe to operate. Be sure all safety guards have been installed before returning the feeder to normal operation. Safety guards on the FT-40-RD or FT-50-RD Feeder include any guards installed by your direct supplier, as well as the guards (which protect the operator from the moving bowl spider, sprockets and chains). (Refer to Figure 1-1 for guard location).



Secure Safety Covers! Before feeder operation, secure all safety covers. Most safety covers are electrically interlocked, and will prevent the machine operation if disengaged.

Operating & Maintenance: Do's & Don'ts

Don't Give the Feeder Too Much Product. Do not overload the feeder, because it may jam or lose rate. Product must be carefully metered into the feeder from bulk. Allow only enough product into the feeder to keep the line running at the required rate.

Don't Run the Feeder Too Fast. Do not run the bowl faster than the linear feet per minute recommended by your direct supplier. If you do, the orientation qualifiers can not do their job as efficiently, and the feeder may jam or lose rate.

Don't Adjust Air Jet Flow Controls. It is okay to adjust the main air regulator to its correct setting for your installation. However, air jets and their individual flow controls have all been carefully preset to work with your product; they should never need adjustment. If you move air jets or adjust their individual flow controls, the feeder may jam or lose rate.

Don't Operate the Feeder Near Flammable Gas, Vapor or Dust. Do not install a feeder in these conditions unless you install additional, approved explosion-proof or dust ignition-proof enclosures. Without such additional enclosures, normal sparking of the brushes inside the motor could ignite flammable gas, vapor or dust.

Do Perform Preventive Maintenance. To keep the feeder running without unexpected repairs and resulting "down" time, regularly perform the preventive maintenance procedures in Chapter 4.



Do Carefully Replace Any Tooling You Remove. To gain access for repairs, you may need to remove tooling. Because Hoppmann and your dealer or OEM have no control over such activities, they can not be responsible for any tooling you remove. **Carefully document the position of any tooling before you begin.** If you fail to replace all tooling exactly as it was, you may create difficult and time consuming problems.

Do Replace Failed Bearings in the Spindle Assembly. The spindle assembly should only be taken apart to replace a failed bearing. Follow the procedures in Chapter 5 for bearing replacement.

Installation & Startup

3

Included this Chapter

Follow, in order, each section of this chapter to install any fully tooled FT-40-RD or FT-50-RD feeder. For your convenience, *Tables 1-2, 1-3, and Figures 3-2 through 3-10* show electrical specifications for your feeder and suggested wiring.

Unpacking, Inspection & Registration



Step 1—Inspect and Unpack the Crate. Remove packing materials from sensors, tooling and moving parts. Make a visual check to be sure parts have not come loose during shipping. If you find any concealed damage, call the shipping carrier and your direct supplier immediately. ***Do not attempt to fix the problem yourself unless told to do so by your direct supplier.***

Step 2—Record Serial Numbers and Register Feeder. If you have not already done so, record on the front of this manual the feeder's model and serial number (also see page 49, Figure 6-1).

Physical Setup

You should refer to as-built drawings (not part of this manual) for electrical, pneumatic and equipment layout specifications.

Step 1—Position the Feeder. Place the feeder as shown on the equipment layout drawing provided by your direct supplier.

Step 2—Level the Feeder. Using a carpenter's level, adjust the leveling feet. Tighten the locknuts on the leveling feet. In some applications, leveling feet are not used because the feeder is connected directly to other framework.

Step 3—Connect the Output Device. Check that product can move smoothly from the exit of the feeder to your output device (deadplate, conveyor, gravity track or powered rollers, for example). Check that product will not jam or lose their orientation as they move to the output device.

Continued ►

Step 4—Position the Prefeeder. Now place your bulk supply hopper, or prefeeder, into position. Follow the equipment layout drawing provided by your direct supplier, or the feeder may not operate correctly. *If you are providing and integrating a prefeeder, continue reading. If your direct supplier is providing and integrating both your feeder and prefeeder, skip to Step 5.*

If you are supplying your own prefeeder, you are responsible for:

- ▶ Providing and installing the feeder's bowl level switch so it can control the flow of your prefeeder.
- ▶ Setting the timing delay for the feeder's bowl level switch.
- ▶ Correctly positioning the prefeeder. Generally, the prefeeder must discharge product to fall on the lowest side of the feeder's rigid disc, halfway between its center and its outside diameter. Take a handful of product and drop them from the snout of your prefeeder into the feeder. Avoid product bouncing up off the rigid disc onto the rim of the bowl, which could knock off product that are already loaded. Position the prefeeder again, if necessary, directing the prefeeder to feed product evenly, after the feeder is running.

Step 5—Connect Power and Air. Connect your feeder to power and compressed air (if applicable). Do not change the feeder's main air regulator; it should already be correct when you receive the feeder.

Starting the Feeder for the First Time

Step 1—Secure Safety Covers and Clothes. Before turning on power and air, make sure safety covers are in place and that you are dressed appropriately for safety.

Step 2—Turn on Power and Air. Turn on the feeder's power. If applicable, turn on the feeder's main air regulator.

Step 3—Check for Rubbing Parts. Run the prefeeder, feeder and output device without product. In the unlikely event that you hear squeaks and squeals (there should be none), shut down immediately and check for any remaining packing, such as between the backup ring and the rim of the bowl.

How to Set Proper Bowl Speed

Ask your direct supplier for the actual linear feet per minute at which the bowl should rotate. For reliability, set the bowl to match that speed.

► You will need a hand-held tachometer (analog or digital) with a surface speed wheel indicator (see Figure 3-1).

► This procedure is performed with power on and the feeder operating. If your direct supplier has installed a cover over the bowl, you will need to open it before proceeding.

Step 1—Turn on Feeder. Turn on the feeder and run it without product.

Step 2—Set Bowl Speed. To set bowl speed, place hand-held tachometer (with surface speed indicator attachment) on the inner wall of the moving bowl, at its most upper inside diameter. Adjust bowl speed until bowl is moving at correct number of linear feet per minute (FPM).

► If you have only one drive motor installed (standard) you can ignore the rigid disc speed, which changes proportionally as the bowl speed changes.

Continued ►

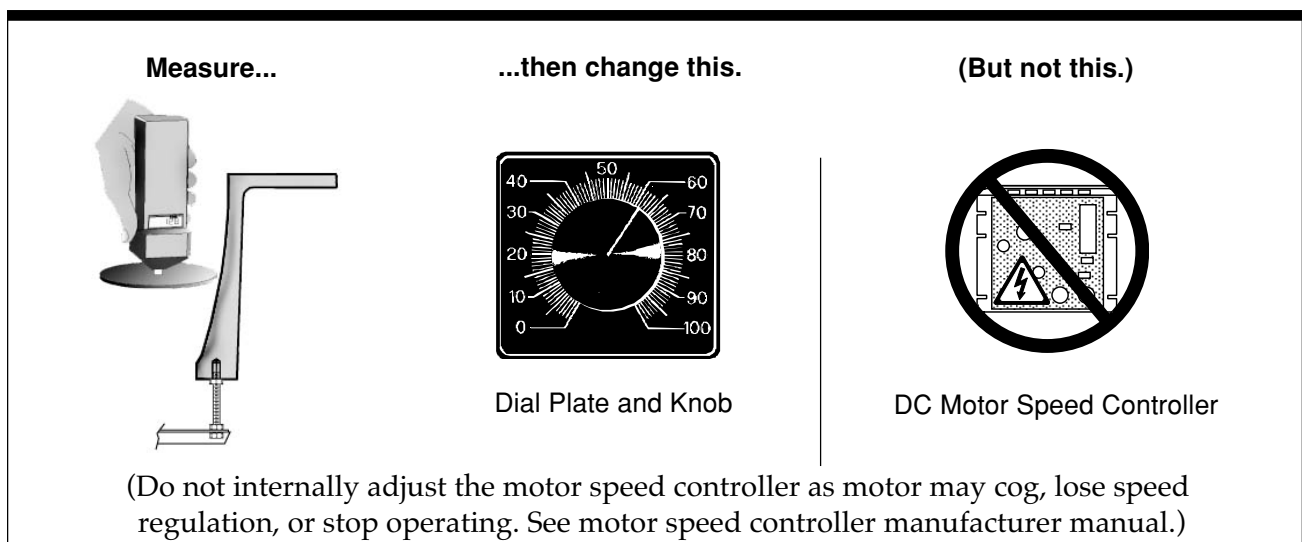

Figure 3-1. Measuring and Changing Bowl Speed

► This procedure assumes your feeder has one drive motor. If your feeder has two drive motors installed, instead of one, repeat this procedure as appropriate for the second drive, measuring the disc speed close to the outer diameter.

Step 3—Record New Settings. Turn off the feeder. Mark dial plate with new setting and remove any old marks.

Running Product for the First Time

Step 1—Verify Changeover Setup. If your feeder is tooled to run multiple product, ensure the feeder is set up for the product you want to run.

Step 2—Inspect Product at Exit. Inspect the exit of the feeder. If product is exiting the feeder properly oriented, at the required rate and without jamming, then installation is complete. Otherwise, continue with Step 3. Don't adjust the flow controls on any air jet.

Step 3—Verify Prefeeder Speed. Normally this step is completed by your direct supplier. However, if you are separately providing and integrating the prefeeder, you will have to set the prefeeder's speed. To do this, turn the prefeeder's speed control all the way down, then turn on the feeder.

► Slowly (you may need to take several minutes) raise the prefeeder's speed control until enough product exit the feeder to keep the line running at the required rate.

► Note: ***Excessive prefeeder output may overload the feeder and reduce its output.***



General Tips

► After your feeder is set up and running, observe the flow of product at each transition point. Later, if a problem occurs, observe these transition points to help pinpoint the cause.

► Listen to the way the feeder sounds when it is running properly. If it suddenly sounds different, investigate why.

AC Metric Single Drive – Wiring Diagram

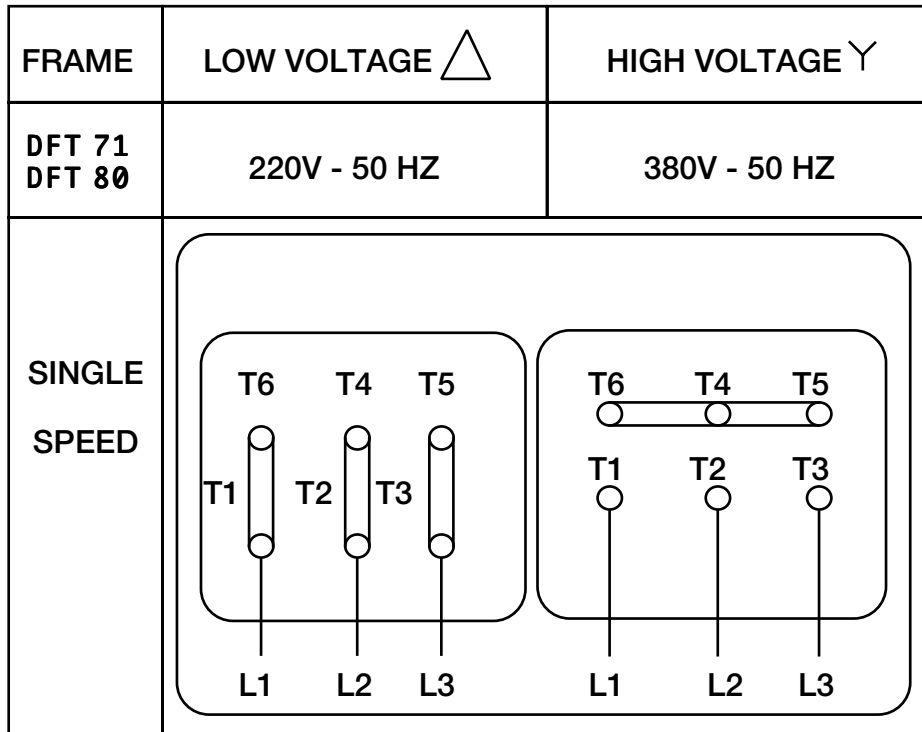

Specifications

Model Inventory Number:	FT401RLACM, FT401RLASM	FT501RLACM, FT501RLASM
Motor	Drive Motor .37 KW 220/380 3PH 50 Hz AC Motor Hoppmann P/N -MOTRMACO5Ø	Drive Motor .55 KW 220/380 3PH 50 Hz AC Motor Hoppmann P/N - MOTRMACO75
Manufacturer	SEW Eurodrive	
Mounting	IEC 71D Face Mounting	
Protection Level	IP54 Protection Level	
Inverter Option	AC Variable Speed Inverter option (not provided with unit). Contact Hoppmann Corporation for inverter specifications and ordering instructions if desired.	

Figure 3-2. FT-40/50-RD AC Metric Wiring Diagram (Single Drive)

AC Metric Dual Drive – Wiring Diagram

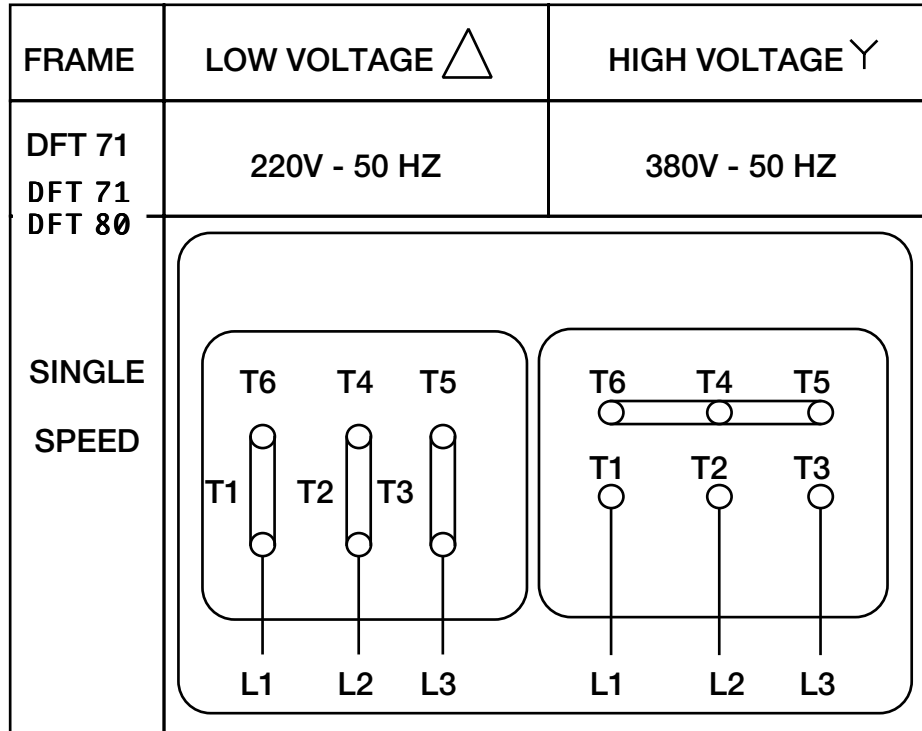

Specifications

Model Inventory Number:	FT402RLACM, FT402RLASM	FT502RLACM, FT502RLASM
Motors	Drive Motor .37 KW 220/380 3PH 50 Hz AC Motor Hoppmann P/N - MOTRMAC050 (2 each)	Bowl Drive Motor .55 KW 220/380 3PH 50 Hz AC Hoppmann P/N - MOTRMAC075 Disc Drive Motor - MOTRMAC050
Manufacturer	SEW Eurodrive	
Mounting	IEC 71D Face Mounting	
Protection Level	IP54 Protection Level	
Inverter Option	AC Variable Speed Inverter option (not provided with unit). Contact Hoppmann Corporation for inverter specifications and ordering instructions if desired.	

Figure 3-3. FT-40/50-RD AC Metric Wiring Diagram (Dual Drive)

DC ANSI Dual Drive – Wiring Diagram

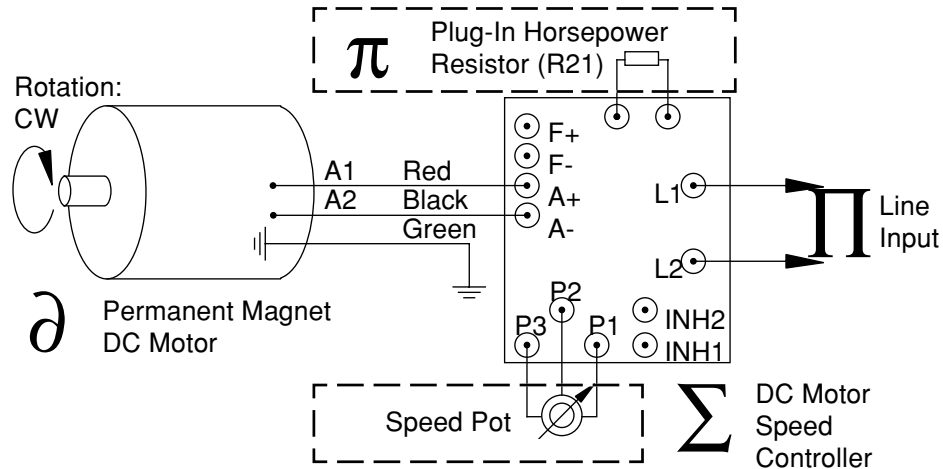

Notes:

- ▶ **Do not use this diagram** if your feeder or motor speed controller are different than shown.
- ▶ **Start-stop options:**
Option 1: Open P3 circuit of speed pot with a pilot duty switch circuit for stop.
Option 2: Interrupt line voltage.
- ▶ **For additional information:** See “KBIC® Solid State DC Motor Speed Control Installation and Operating Instructions” available in North America from KB Electronics, Inc., Brooklyn, New York; in the United Kingdom from EUREP, Lichfield Staffs; in Germany from Moll Motor Motors, Donaustrasse, Austria or Suter Form-O-Tronic AG, Zurich, Switzerland.

Specifications

Model Inventory Number:	FT402RLDCA, FT402RLDSA	FT502RLDCA, FT502RLDSA
Motors	Drive Motor - 1/2 HP, 90VDC Hoppmann P/N - MOTRPM0102 (2 each)	Bowl Drive Motor - 3/4 HP, 90 VDC Hoppmann P/N - MOTRPM0304 Disc Drive Motor Hoppmann P/N - MOTRPM0102
DC Motor Speed Controller	KBIC-118-218	
Line Input	115 VAC	
Plug In Horsepower Resistor (R21)	0.025 Ohm, 1/2 H.P. 0.015 Ohm, 3/4 H.P.	

Figure 3-4. FT-40/50-RD DC ANSI Wiring Diagram (Dual Drive)

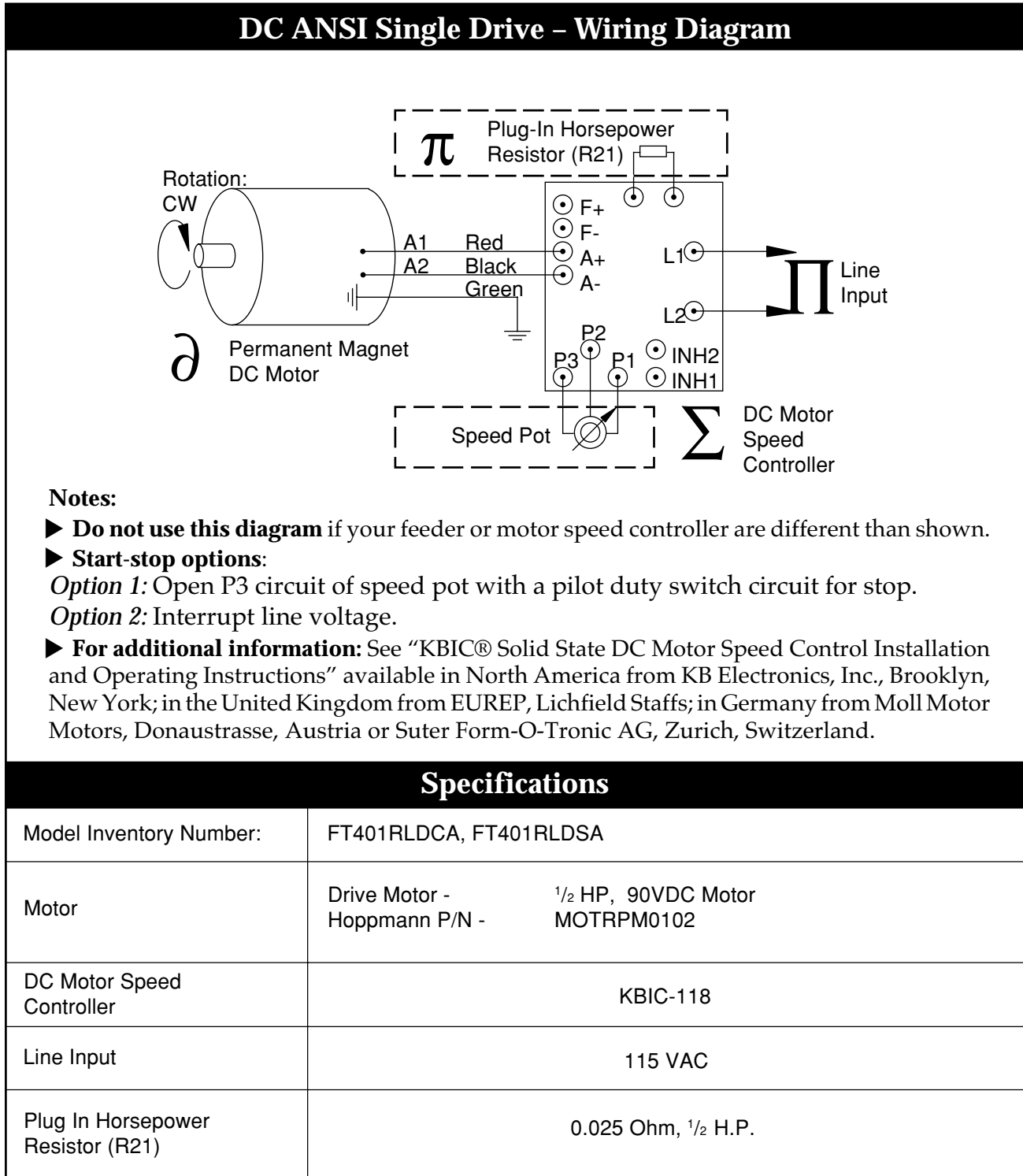

Figure 3-5. FT-40-RD DC ANSI Wiring Diagram (Single Drive)

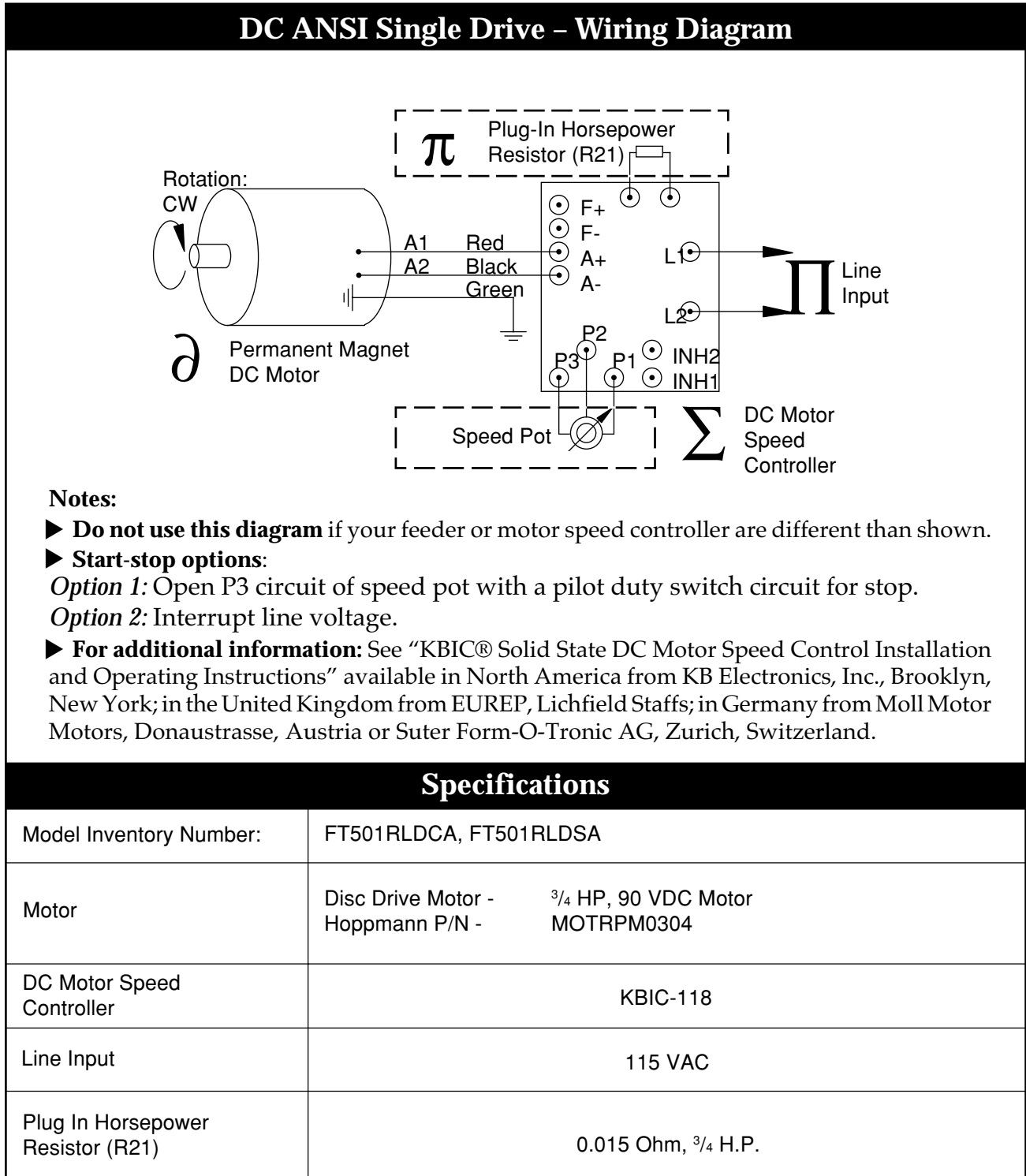
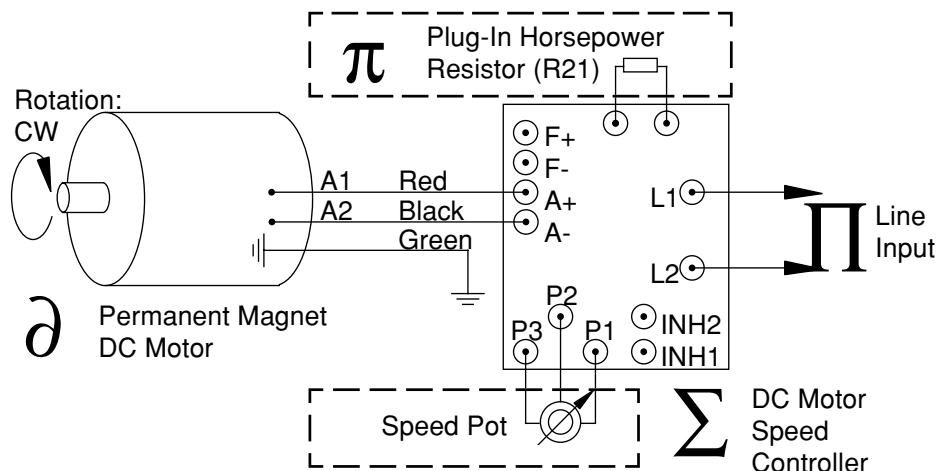

Figure 3-6. FT-50-RD DC ANSI Wiring Diagram (Single Drive)

DC Metric Single Drive – Wiring Diagram



Notes:

- ▶ **Do not use this diagram** if your feeder or motor speed controller are different than shown.
- ▶ **Start-stop options:**
 - Option 1:* Open P3 circuit of speed pot with a pilot duty switch circuit for stop.
 - Option 2:* Interrupt line voltage.
- ▶ **For additional information:** See “KBIC® Solid State DC Motor Speed Control Installation and Operating Instructions” available in North America from KB Electronics, Inc., Brooklyn, New York; in the United Kingdom from EUREP, Lichfield Staffs; in Germany from Moll Motor Motors, Donaustrasse, Austria or Suter Form-O-Tronic AG, Zurich, Switzerland.

Specifications

Model Inventory Number:	FT401RLDCM, FT401RLDSM	FT501RLDCM, FT501RLDSM
Motor	Drive Motor - .37 KW (1/2 H.P.) 180VDC Motor Hoppmann Part No. MOTRM.50HP	Drive Motor - .55 KW (3/4 H.P.) 180VDC Motor Hoppmann Part No. MOTRM.75HP
DC Motor Speed Controller	KBIC - 118-240	
Line Input	208 - 240 VAC	
Plug In Horsepower Resistor (R21)	0.05 Ohm, 1/2 H.P.	0.035 OHM, 3/4 H.P.

Figure 3-7. FT-40/50-RD DC Metric Wiring Diagram (Single Drive)

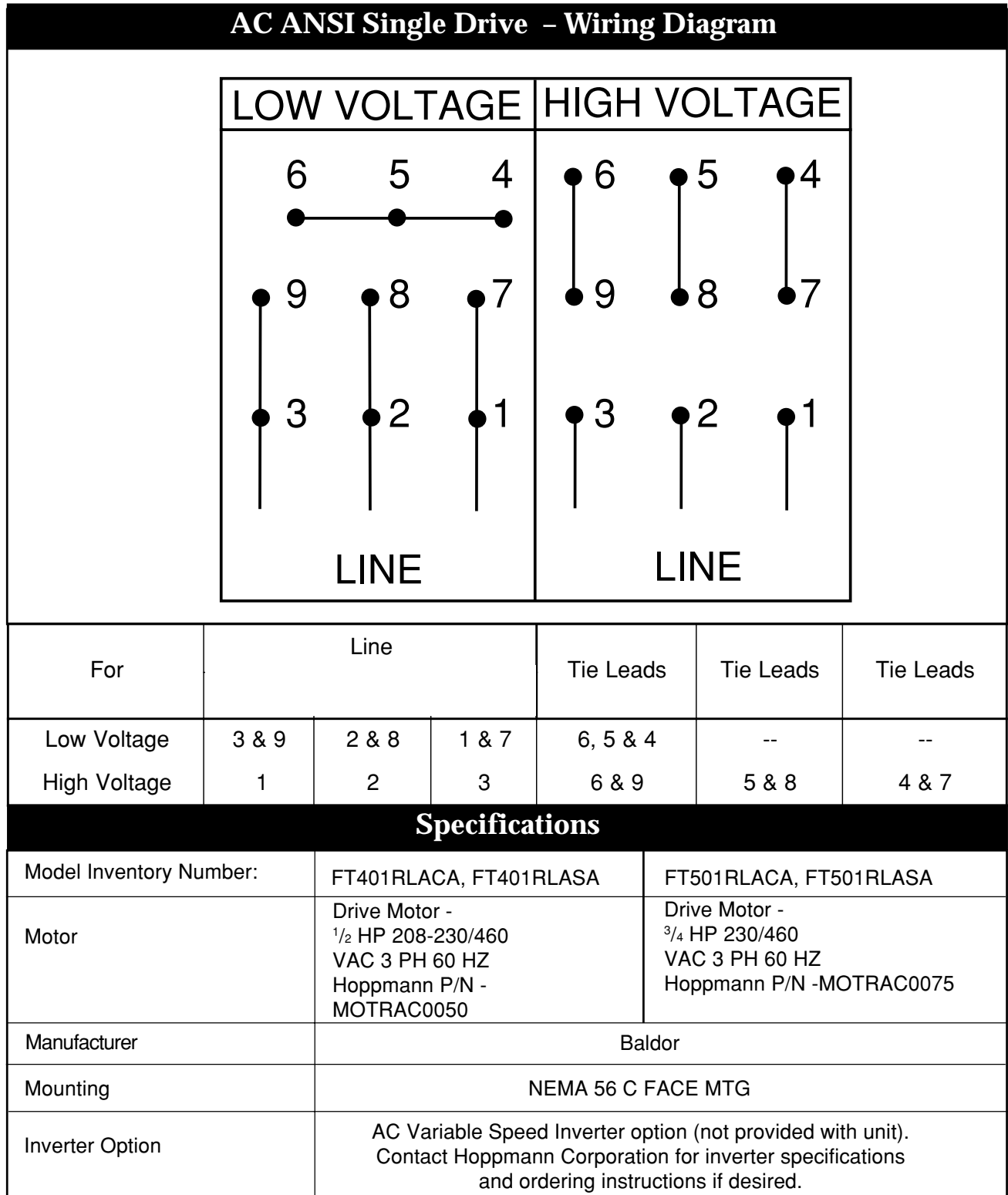
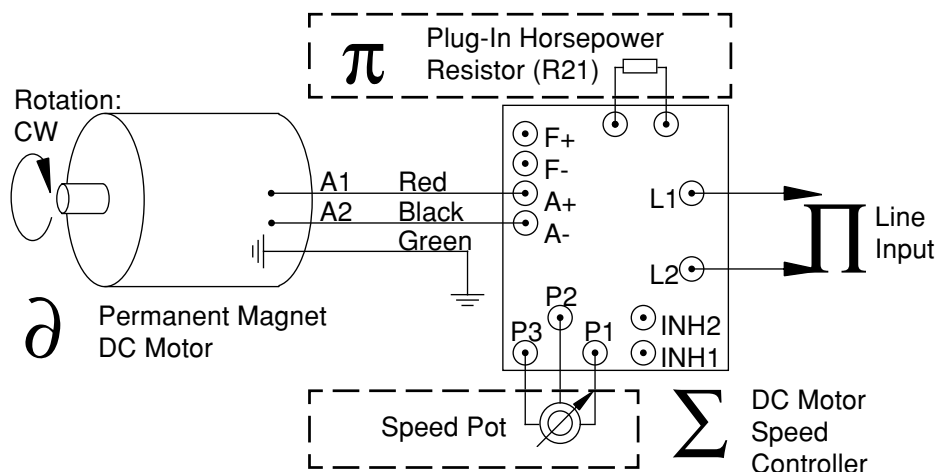

Figure 3-8. FT-40/50-RD AC ANSI Wiring Diagram (Single Drive)

DC Metric Dual Drive – Wiring Diagram



Notes:

- ▶ **Do not use this diagram** if your feeder or motor speed controller are different than shown.
- ▶ **Start-stop options:**
Option 1: Open P3 circuit of speed pot with a pilot duty switch circuit for stop.
Option 2: Interrupt line voltage.
- ▶ **For additional information:** See “KBIC® Solid State DC Motor Speed Control Installation and Operating Instructions” available in North America from KB Electronics, Inc., Brooklyn, New York; in the United Kingdom from EUREP, Lichfield Staffs; in Germany from Moll Motor Motors, Donaustrasse, Austria or Suter Form-O-Tronic AG, Zurich, Switzerland.

Specifications

Model Inventory Number:	FT402RLDCM, FT402RLDSM	FT502RLDCM, FT502RLDSM
Motor	Disc Drive Motor - .37 KW (1/2 H.P.) 180VDC Motor Hoppmann P/N - MOTRM.50HP (2 each)	Bowl Drive Motor - .55 KW (3/4 H.P.) 180VDC Motor Hoppmann P/N - MOTRM.75HP Disc Drive Motor - MOTRM.50HP
DC Motor Speed Controller	KBIC-118-218	
Line Input	240 VAC	
Plug In Horsepower Resistor (R21)	0.05 Ohm, 1/2 H.P.	0.035 OHM, 3/4 H.P.

Figure 3-9. FT-40/50-RD DC Metric Wiring Diagram (Dual Drive)

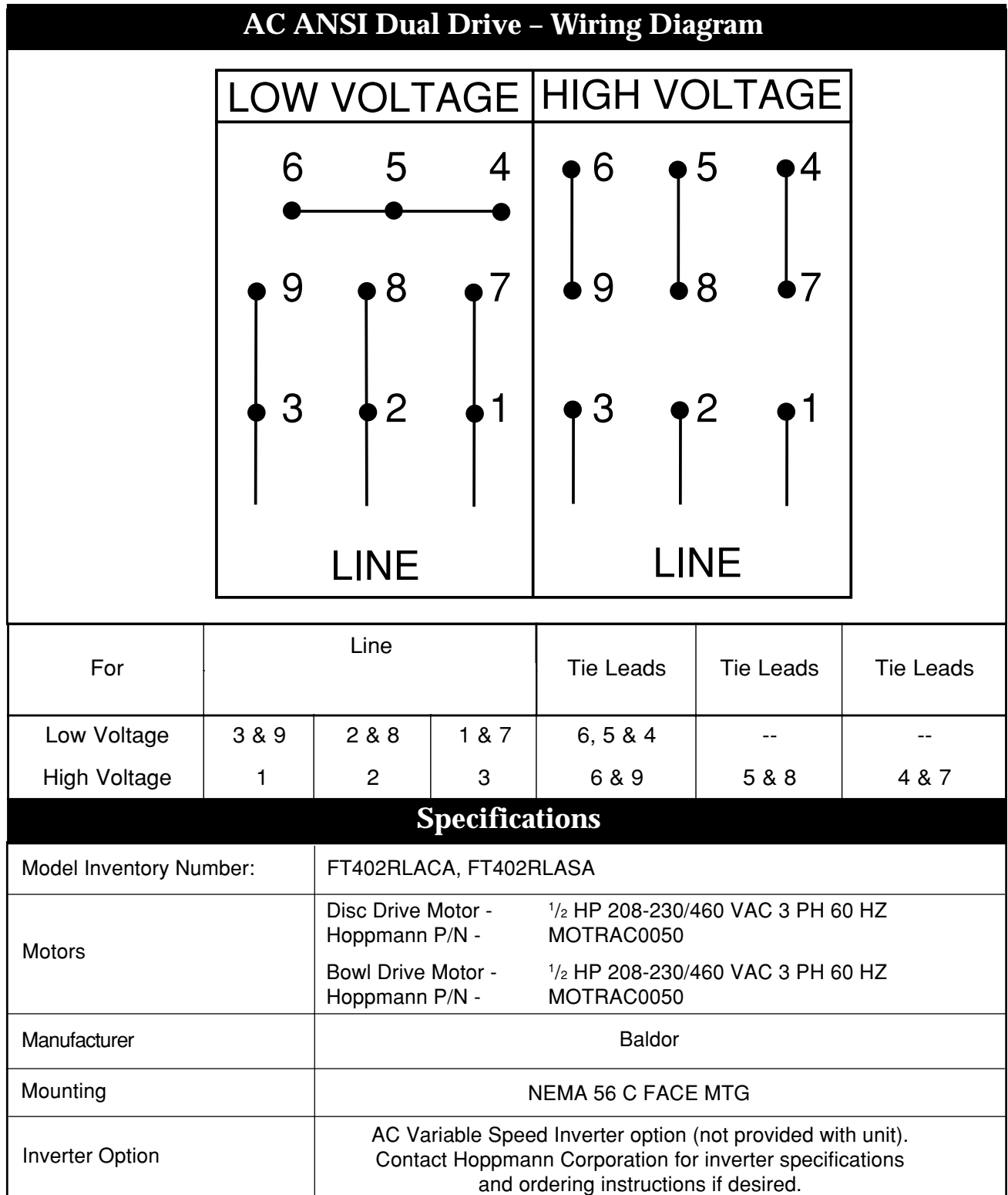

Figure 3-10. FT-40-RD AC ANSI Wiring Diagram (Dual Drive)

Notes

Preventive Maintenance

4

General Cleaning

Outer Frame & Tooling

The Hoppmann Model FT-40/50-RD Centrifugal Feeder is **not** intended for washdown use. If you need to clean the **outer frame**, the **rim of the bowl**, the **rigid disc**, or **tooling**, use mild household cleaners.

Bowl & Rigid Disc: "Dusty" Applications

The bowl and disc are self-cleaning when handling most parts. However, if your parts generate dust or particulate when handled, clean the feeder as often as necessary. For such parts, remove dust from the top surface of the rim of the bowl and the rigid disc with a portable vacuum cleaner or dry compressed air.

Changing Gear Oil in ANSI Speed Reducer

The gear reducer manufacturer recommends that you change the gear oil after the first 1500 hours of operation, and then after every 500 hours of operation. It's recommended that all other maintenance procedures, for both metric and ANSI models, are performed six (6) months after installation.



If you do not regularly change the gear oil in the ANSI FT-40-RD or FT-50-RD feeder, the speed reducer will eventually fail. This type of failure is not covered under warranty.

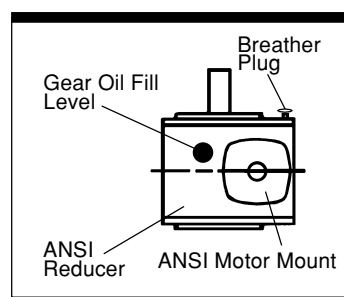

Figure 4-1.
Gear Oil Fill Level

► The speed reducer in the ANSI FT-40-RD or FT-50-RD feeder requires periodic maintenance; the speed reducer in the metric FT-40-RD or FT-50-RD feeder does not.

► You should change the gear oil after the first 250 hours of operation, and then after every 2500 hours or every six months, whichever comes first. You may need to change the gear oil more often if you run the FT-40-RD or FT-50-RD feeder in a room which is unusually hot or dirty.

► Check the level of gear oil before draining (see Figure 4-1). If the level is low, check the reducer's input and output shaft seals for leaks.

► Drain the gear oil while warm; the gear oil will drain more easily than if cold. If there are any metal contaminants, they are less likely to remain behind.

► Refill to the correct level with the recommended gear oils (see Figure 4-2). The gear oils shown are specifically for the worm gear speed reducer in the ANSI FT-40-RD or FT-50-RD feeder; other gear reducers may require different types of gear oil.

Tip: The ANSI FT-40-RD or FT-50-RD feeder is shipped to your direct supplier with synthetic gear oil. Because synthetic gear oil has increased resistance to heat and oxidation, it does not have to be changed as often as conventional gear oil. You should change the oil after the first 1500 hours of operation, and then after every 5000 hours.

Metric Speed Reducer—No Lubrication Required. The speed reducer used in the metric FT-40-RD or FT-50-RD feeder is lubricated for life with synthetic lubricant and requires no regular maintenance.

Speed Reducer Gear Oil FT-40-RD & FT-50 RD Centrifugal Feeders - ANSI			
Recommended Gear Oil or equivalent	Mobil "600W Cylinder Oil" (Standard)	Mobil "Extra Hecla Super Cylinder Oil"	Mobil "SHC 634 Synthetic"
Ambient (Room) Temp.	40 to 90° F (4 to 32° C)	80 to 125° F (27 to 52° C)	-30 to +125° F. (-34 to +52° C)
Viscosity Range SUS at 100° F.	1920/3200	2850/3600	1950/2150
AGMA No.	7 or 7C**	8 or 8C**	*
ISO*** Viscosity Grade	460	680	320/460
<p>* Mobil SHC 634 is the only synthetic gear oil we recommend. ** Ask for equivalent gear oil by AGMA number from most major oil companies. *** International Organization For Standardization, Switzerland</p>			

Figure 4-2. Recommended Gear Oil

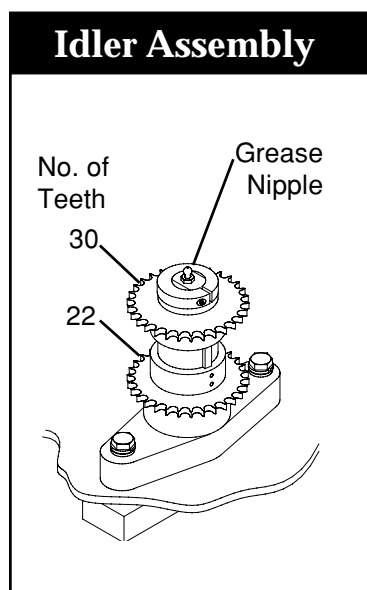

Figure 4-3. Assembled View

Idler Assembly Maintenance

It's recommended that you grease the idler assembly, for both metric and ANSI single drive models, every six (6) months after installation. Note the order of assembly (see Figure 5-2 on page 41.)

Chains and Sprocket Lubrication

On all FT-40-RD or FT-50-RD feeders, grease the disc and rim drive chains and sprockets every six months or 1000 operating hours, whichever comes first.

- ▶ Before beginning, disconnect power and air. Remove exit cover and exit support assembly to gain access.
- ▶ Use standard Moly grease, Lubriplate #3000 (NLGI Grade 2) or equivalent. Turn bowl by hand to expose all links of bowl drive chains.
- ▶ Expose all links of the drive chains by jogging the feeder (turning it on and off). Lock and tag out the FT-40-RD or FT-50-RD feeder while you are lubricating the chain.

Inspect Chain Tension

Step 1—Gain Access. Improper chain tension wears out sprockets and chains. When lubricating or performing other maintenance tasks, inspect the tension of the chain. If you have not already done so, disconnect power and air, and remove the exit cover and the exit support assembly to gain access.

Step 2—Inspect Drive Chain. Midway between sprockets, grasp each chain and wiggle it back and forth. You should be able to move it no more than a total of 1" (25 mm) as shown in Figure 4-4.

Continued ▶

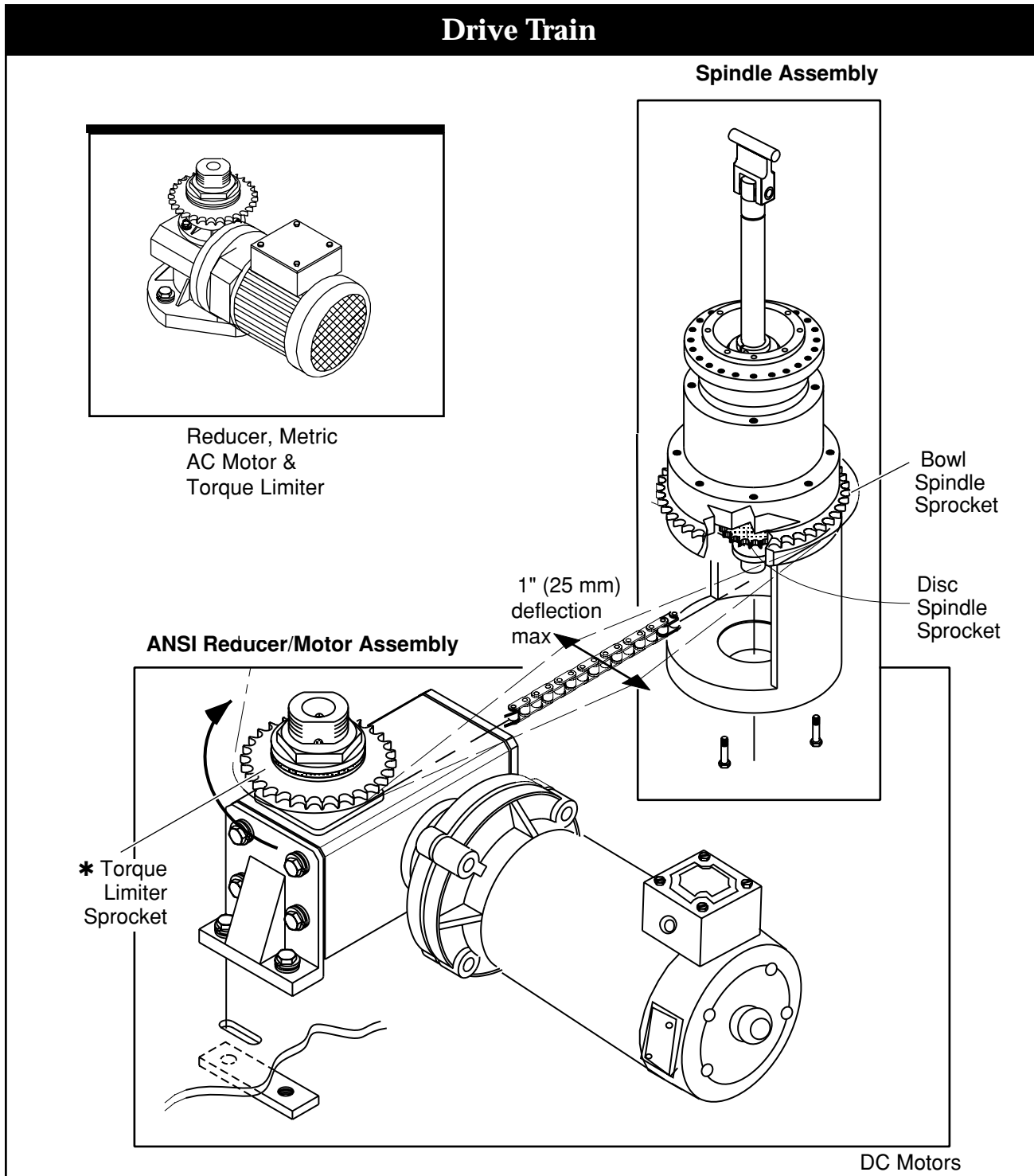

Figure 4-4. FT-40/50-RD Drive Train

► If adjustment is needed, loosen the reducer mounting brackets from the nut plates. Move the reducer forward or back as necessary and then retighten.

Step 3—Check for Parallel Sprockets. Check that each set of sprockets is parallel to within $1/32$ " (0.8 mm). If not parallel, realign only the idler sprockets.

Step 4—Check for Vibration. Run the feeder. If vibration is evident, check chain tension for excessive tightness. Vibration may be reduced or eliminated by the realignment of sprockets and increase of total chain deflection from 1" (25 mm) to $1\ 1/4$ " (32 mm).

Step 5—Replace Covers. Replace covers and connect power and air. Initial and date the Maintenance Log (page 52).

Inspect/Replace Motor Brushes



The following procedure applies only to DC motors and should be performed only by qualified personnel. Refer motor repairs to a motor repair specialist.

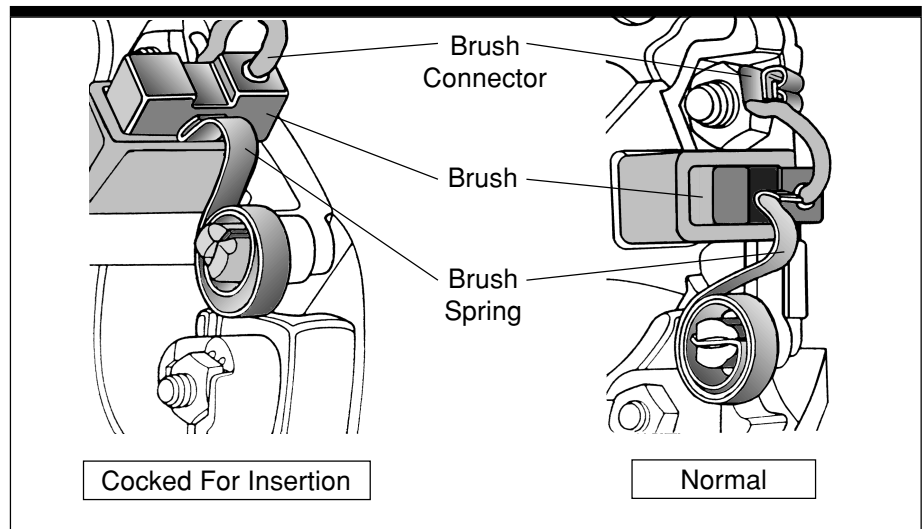

Figure 4-5. DC Motor Brushes (Gasketed Cover Removed)



Step 1—Record Brush Length. To prevent motor damage, brushes should be replaced when or before they reach half the original length. ***Inspect brush length when equipment is new, and record new brush length. Indicate 1/2 that length as the replacement mark.***

Step 2—Gain Access. Disconnect power and air. Remove feeder covers as needed to gain access to the motor, then remove the motor brush access covers.



Step 3—Clean the Motor. Clean the motor by blowing into the open access hole with compressed air. ***Eye protection should be worn to prevent any particles from blowing into the eyes.***

Step 4—Replace Brushes. Lift the brush spring from the end of the brush (see Figure 4-5). Remove the brush connector, withdraw the brush and inspect the length. To prevent motor damage, brushes should be replaced when or before they reach the half way point. Reverse procedure to replace brush. Replace motor access and feeder covers. Connect power and air. Initial and date the Maintenance Log.

Repair & Troubleshooting

5

Torque Limiter: Adjustment/Replacement

The torque limiter allows the drive sprocket to slip harmlessly in the event of a product jam. Severe humidity or dryness, lubricants or surface corrosion on bushings or the drive sprocket may reduce the effectiveness of the torque limiter. The torque limiter should be inspected and adjusted if the rim is free wheeling.

Step 1—Disconnect power. Turn off power and air.

Step 2—Gain Access. Remove exit cover and rim drive chain.

Step 3—Remove Torque Limiter. Remove and disassemble torque limiter (see Figure 5-1.) Inspect and replace any broken or worn parts. Observe order of components.

Step 4—Assemble Torque Limiter. Clean parts before re-assembly. Assemble the torque limiter. Tighten adjusting nut hand tight. Do not completely flatten the disk spring.

Step 5—Install Torque Limiter. Install the torque limiter. Tighten the adjusting nut (see Figure 5-1) down until the bowl turns when power is applied with minimum slippage. Do not completely flatten the disk spring. Also do not lock the adjusting nut yet. You will lock the adjusting nut after turning on the motor. Some slippage must occur to prevent damage, however, there should be no slippage if the bowl is at maximum rotation.

Step 6—Replace Chain. Replace chain and inspect chain tension (refer to Figure 4-4 on page 31).

Step 7—Lock Adjusting Nut. Lock the adjusting nut by bending a lockwasher tab over it. Make sure any safety covers you removed have been replaced. The FT-40-RD or FT-50-RD feeder is ready for use.



Note: *Some slippage must occur to prevent damage, however, there should be no slippage if the bowl is at maximum rotation.*

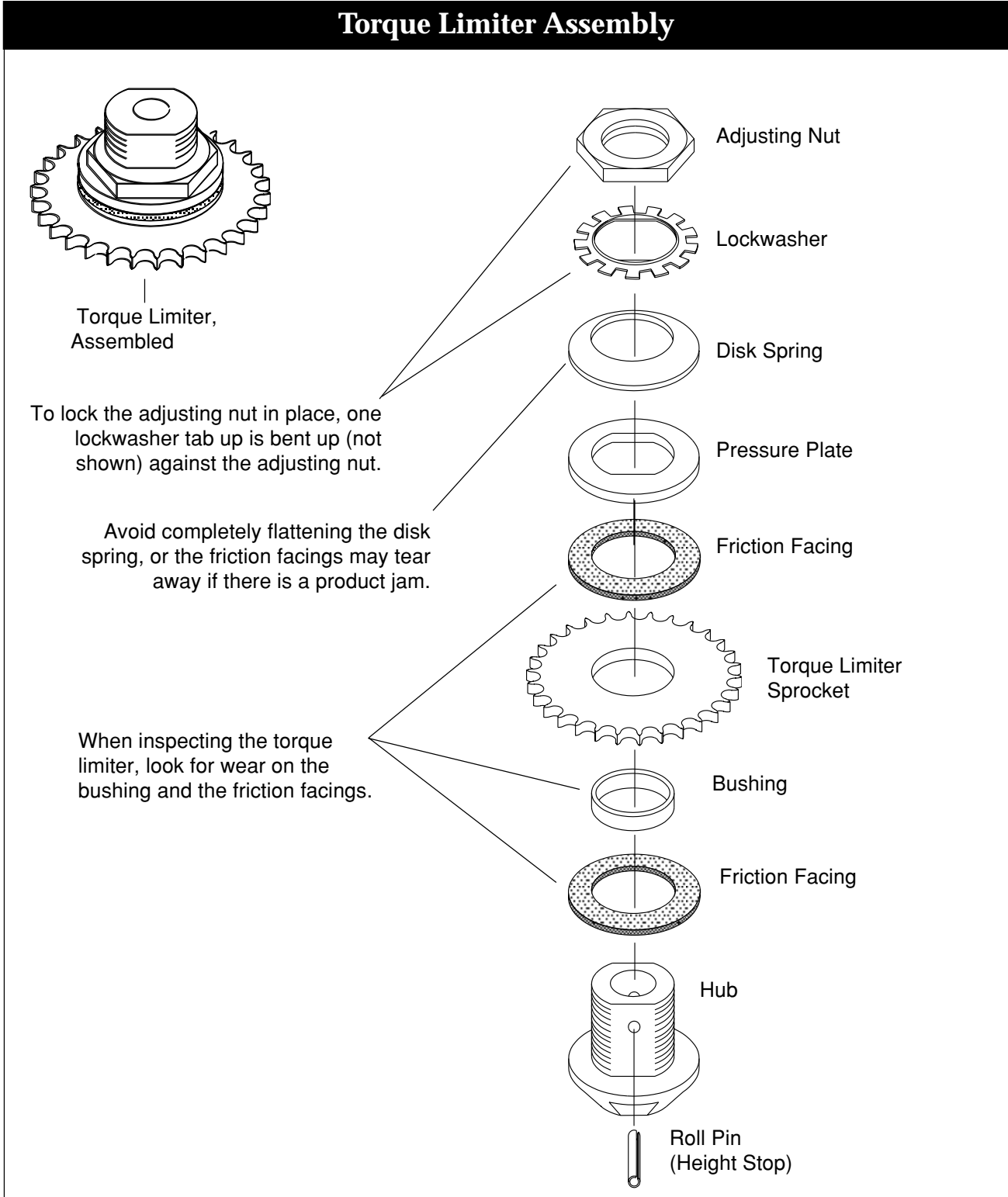

Figure 5-1. Torque Limiter Assembly

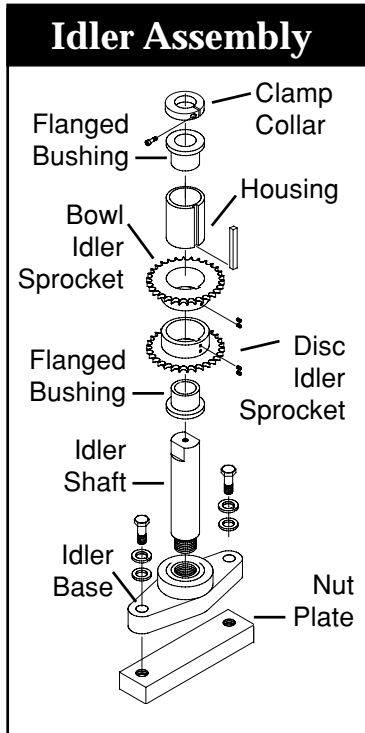

Figure 5-2. Idler Assembly

Idler Assembly Component Replacement

If component replacement is necessary note the order of assembly in (Figure 5-2).

Replacing or Refinishing a Damaged Bowl

If the bowl becomes damaged in a way that adversely affects the feeder performance, the bowl must be replaced or refinished.

► If the damage is slight, recoating with commercial hard coat by a professional metal refinisher may correct the problem.

► Machining must be done in such a way that bowl runout is restored to original tolerances, or the feeder may not operate correctly. If machining is necessary, have the bowl recoated. Recoating the bowl retains the USDA/FDA approved (ultra-hard protective) product contact surface, and corrosion resistance of the bowl.

► If machining enlarges the inner diameter of the bowl, you may need to replace the disc with a larger one (custom-sized) from your direct supplier. If you do not obtain a larger disc, the gap between the disc and the inner diameter of the bowl may pinch or snag product (see Figure 5-3).

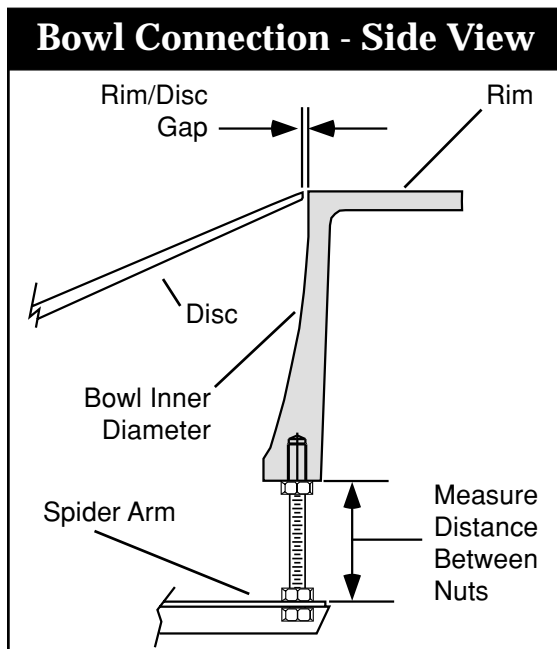

Figure 5-3. Side View - Bowl Connection

Step 1—Measuring and Removing the Bowl.

Measure the height between the bottom of the bowl, and the top of the spider arm (where the threaded rod connects the two parts - see Figure 5-3). Loosen and remove the bottom nut on the spider arm (on each of the eight (8) arms) and remove the bowl - pulling it up and away from the feeder.

Step 2—Replacing the Bowl.

Put the new or refinished bowl in place, then set it to the correct height, $\pm 0.03''$ (0.8 mm) as you measured in Step 1.

Step 3—Bowl Runout. Refer to page 32 to set bowl runout.

Step 4—Check Covers. Check that all covers are in place before running the feeder.

How to Set Bowl Runout

Bowl runout needs to be reset if the bowl has been removed. Adjust runout with power off and bowl drive chain disengaged.

Step 1—Gain Access. Disconnect power and air. Remove any frame covers.

Step 2—Remove Bowl Drive Chain. Remove the master link. Disconnect the bowl drive chain from the bowl spindle sprocket.

Step 3—Adjust Vertical Runout. Attach a dial indicator to the inside of any upper frame support. Set the indicator contact point vertical, perpendicular to the rim of the bowl, up to ¼" (6 mm) from the bowl's upper inside diameter (ID). Loosen jam nuts and locknuts above and below each arm of the bowl spider one arm at a time. Repeat as often as necessary while checking runout. Do not tighten jam nuts until Step 4.

Step 4—Adjust Horizontal Runout. Move the indicator contact point horizontal, perpendicular to the inner wall of the bowl, up to ¼" (6 mm) from the bowl's upper ID. Gently tap the bowl's ID with the palm of your hand or a rubber mallet. Tighten locknuts and jam nuts by hand firmly but not forcibly. Inspect vertical runout and adjust again if necessary. Continue alternating between horizontal and vertical runout until both are within specification.

Step 5—Check Exit. Ensure that proper relationship still exists at transition between rim of bowl and output device (deadplate, conveyor, gravity track, or powered rollers, etc.).

Continued ►

Step 6—Check Backup Ring Clearance. Ensure that proper, as-tooled gap still exists between bottom of backup ring and rim of the bowl. (Feeders for most products are tooled with approximately $\frac{1}{8}$ " gap, but for some small products the gap is less; consult your as-built documentation for specifications.) At the upper frame support, adjust the tooling ring up or down, if necessary.

Step 7—Replace Chain & Covers. Install bowl drive chain. Inspect chain tension (see Figure 4-4 on page 31). Replace covers and re-connect power and air.

ANSI Speed Reducer: Replacement

Follow these instructions to replace the ANSI speed reducer with its direct replacement.

Step 1—Gain Access. Disconnect power and air. Remove the exit cover.

Step 2—Remove Motor. Remove mounting bolts and then remove motor from the speed reducer, leaving wiring intact. Set motor off to the side on secure support mount.

Step 3—Remove Old Speed Reducer. Remove the two mounting bolts on each nut plate at the bottom of the reducer mounting brackets. Slide the speed reducer towards the center of the FT-40-RD or FT-50-RD feeder, and remove the chain. Completely remove the speed reducer assembly.

Step 4—Reducer Installation. Remove the torque limiter and reducer mounting brackets from the old reducer and install them on the new reducer. Slide the torque limiter assembly down onto the reducer output shaft until it bottoms out against the roll pin (see Figure 5-1). Tighten setscrew.

Step 5—Check and Install Gear Oil. Unpack the new speed reducer. Leave rubber sleeves on shafts to protect your hands from any sharp edges on the keyways. Fill the new speed reducer to the correct level with gear oil. Keep the speed reducer level as you

Continued ►

FT -40/50-RD ANSI Speed Reducer & Motor Assembly

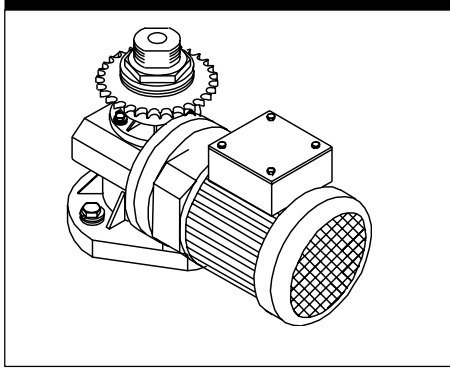

Reducer, Metric
AC Motor &
Torque Limiter

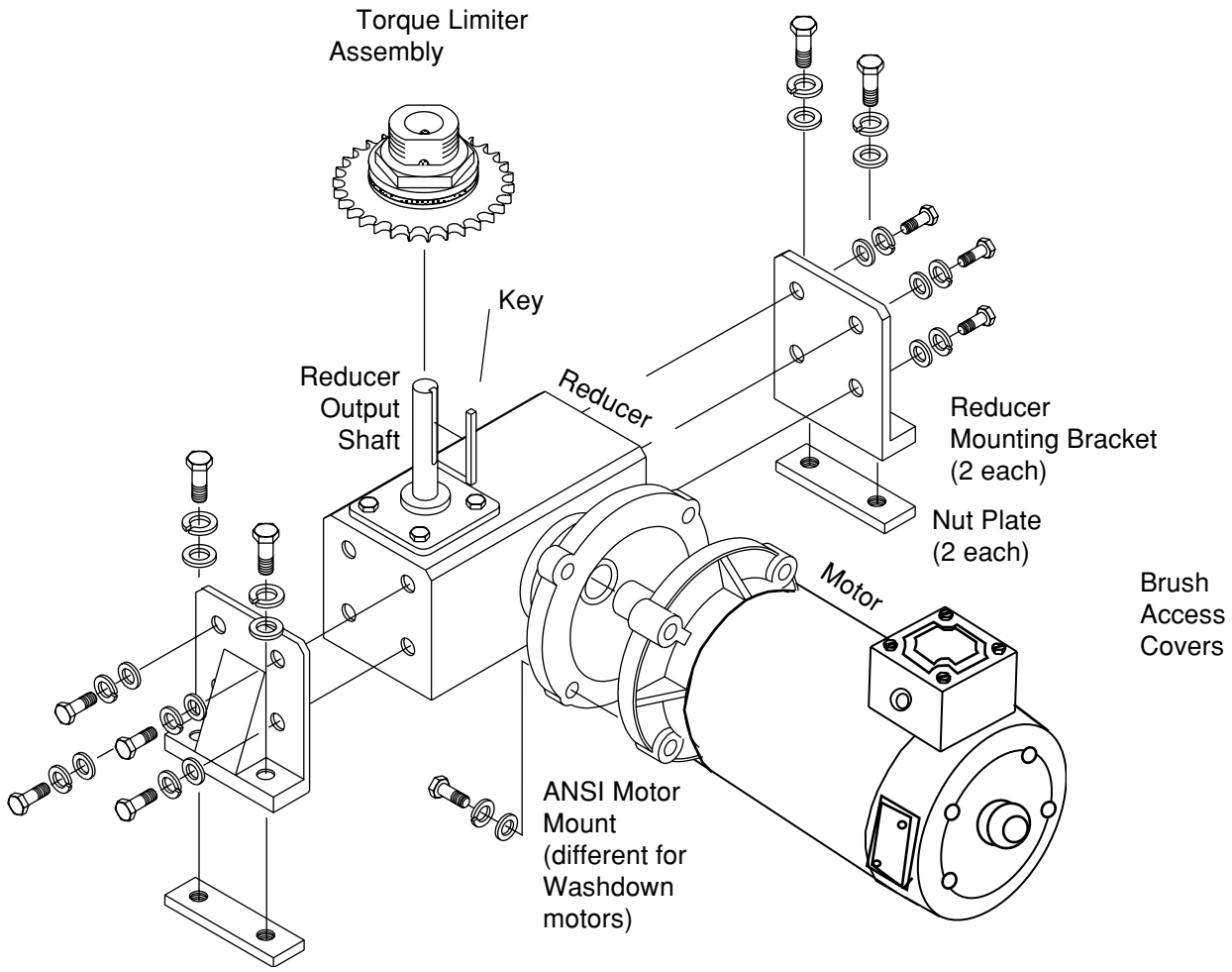

Figure 5-4. FT-40/50-RD Feeder Speed Reducer & Motor

install it, or the breather hole may leak (see Figure 4-1). Recommended gear oil is listed in Chapter 4.



Step 6—Install New Speed Reducer. Install new reducer assembly back into the feeder and reattach the two nut plates, securing the assembly to the frame. ***Do not tighten the nut bolts yet.***

Step 7—Install Motor. Assemble the key to the motor shaft and coat the shaft with anti-seize compound. Insert the motor shaft into the speed reducer input shaft. Align the shafts accurately; improper alignment can result in failure. Do not allow the motor to "hang" unsupported before fully seated in the reducer to avoid damaging the reducer input seal. Rotate the motor to the correct position and firmly secure to flange with four hex-head cap screws. If the motor does not readily seat itself, check to see if the key has moved.

Step 8—Adjust. Reattach drive chain and re-tension, checking sprocket alignments and wiring to insure no damage has occurred. Tighten the nut plate bolts to the frame.



Step 9—Inspect After Installation. During the speed reducer's break-in period, it may run hotter than normal. ***Nevertheless, for maximum life, do not allow the speed reducer to operate continuously above 225°F at the gear case (for AC motors used in Europe, it is customary to use 60°C maximum).*** In the event of overheating, check for overloads or high ambient temperatures. Keep shafts and vent plugs clean to prevent foreign particles from entering the speed reducer. Periodically inspect all bolts to make sure they are not loose.

Metric Speed Reducer: Replacement

Follow these instructions to replace the metric speed reducer with its direct replacement.

Step 1—Gain Access. Disconnect power and air. Remove the exit cover.

Continued ►

Step 2—Remove Motor. Remove mounting bolts and then remove motor from the speed reducer, leaving wiring intact. Set motor off to the side on secure support mount.

Step 3—Remove Old Speed Reducer. Remove the two mounting bolts on each nut plate at the bottom of the reducer mounting brackets. Slide the speed reducer towards the center of the FT-40-RD or FT-50-RD feeder, and remove the chain. Completely remove the speed reducer assembly.

Step 4—Reducer Installation. Remove the torque limiter and reducer mounting bracket from the old reducer and install on the new reducer.

Step 5—Assemble Output Shaft. Unlike the ANSI speed reducer, which includes an integral output shaft, the output shaft on the metric speed reducer comes as a separate kit. If replacement is required, clean both contact surfaces before assembly and apply any appropriate anti-seize compound to avoid oxidation (rust) and possible seizing of parts. Slide the torque limiter assembly down onto the reducer output shaft until it bottoms out against the roll pin (see Figure 5-1). Tighten setscrew. The speed reducer used in the metric FT-40-RD or FT-50-RD feeder is lubricated for life with synthetic lubricant and requires no filling before use.



Step 6—Install New Speed Reducer. Install new reducer assembly back into the feeder and reattach the two nut plates, securing the assembly to the frame. ***Do not tighten the nut bolts yet.***

Step 7—Install Motor. Assemble the key to the motor shaft and coat the shaft with anti-seize compound. Insert the motor shaft into the speed reducer input shaft. Align the shafts accurately; improper alignment can result in failure. Rotate the motor to the correct position and firmly secure to flange with four hex-head cap screws. Do not allow the motor to "hang" unsupported before fully seated in the reducer to avoid damaging the reducer input seal. If the motor does not readily seat itself, check to see if the key has moved.

Step 8—Adjust. Reattach drive chain and re-tension, checking sprocket alignments and wiring to insure no damage has occurred. Tighten the nut plate bolts to the frame.



Step 9—Inspect After Installation. During the speed reducer’s break-in period, it may run hotter than normal. **Nevertheless, for maximum life, do not allow the speed reducer to operate continuously above 225°F at the gear case (for AC motors used in Europe, it is customary to use 60°C maximum).** In the event of overheating, check for overloads or high ambient temperatures. Keep shafts and vent plugs clean to prevent foreign particles from entering the speed reducer. Periodically inspect all bolts to make sure they are not loose.

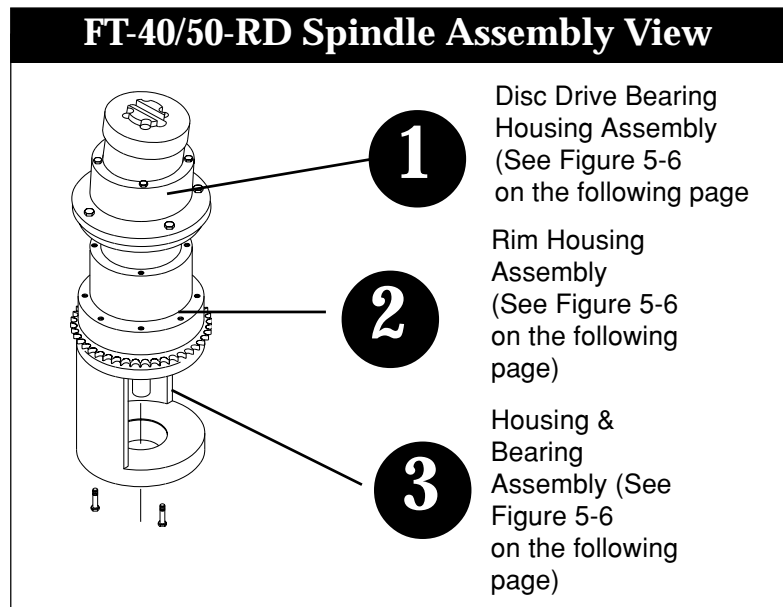

Figure 5-5. FT-40/50-RD Feeder Spindle Assembly

Major Bearing Replacement

Major bearings in the FT-40-RD or FT-50-RD feeder are the upper and lower disc shaft spindle bearings, the upper and lower rim support spindle bearings and the disc support bearing (see Figures 5-5 and 5-6). All major bearings except the disc shaft spindle bearings are identical.

Continued ►

FT-40/50-RD Assembly Views

1 Disc Drive Bearing Housing Assembly, Exploded View

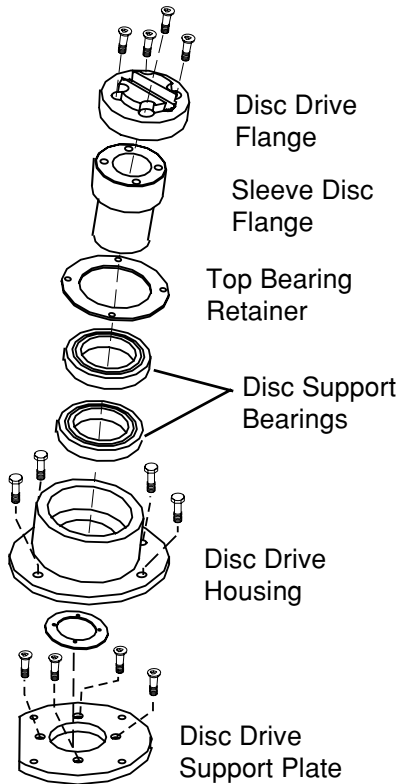

2 Rim Housing Assembly - Exploded View

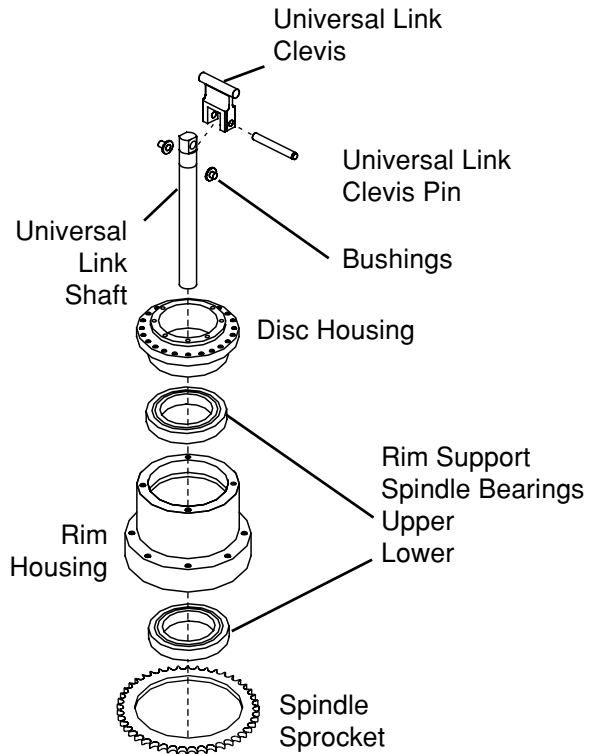

3 Housing Bearing Assembly - Exploded View

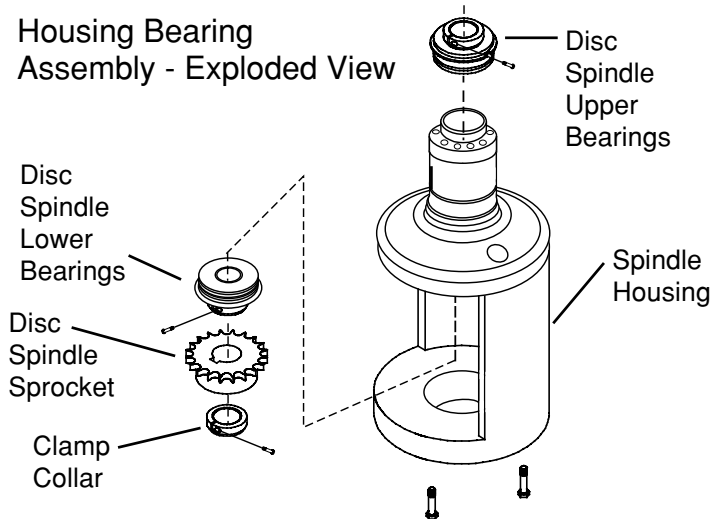

Figure 5-6. FT-40/50-RD Spindle Assembly - Exploded Views

**Major Bearing Replacement Cautions:**

▶ Eliminate other possible problems before attempting bearing replacement, as substantial disassembly of the feeder is required.

Carefully note position of any tooling you remove before you begin. Keep chains clean and dry after removal.

▶ Most major bearings in the FT-40-RD or FT-50-RD are preloaded to prevent play. To prevent binding or excessive free play in the bowl, ensure that all bearing housings and the bearings themselves are clean and free of external grease, dirt, nicks or burrs prior to reassembly. If you accidentally damage critical surfaces of the housings, you may need to replace the entire spindle assembly as a unit.

▶ Install only 100% identical replacement bearings. In the unlikely event that the bowl will not turn, or that there is play in the bowl when you are done, you may need to replace the spindle assembly as a unit, or contact Hoppmann Corporation for assistance.

▶ To maintain accuracy and prevent play in the bowl, replace both bearings of a pair at the same time. Do not replace only one.

▶ Do not swap housings (such as the disc shaft spindle bearing housing) from one FTF feeder to another, as critical surfaces may have been custom-machined for zero play in the bowl.

If Product Jams: General Tips

Step 1—Inspect The Feeder. If product jams repeatedly, review the following:

▶ Is the prefeeder delivery rate excessive? (The prefeeder should deliver only enough product to the feeder to keep the line running at the required rate.)

▶ Is the feeder's bowl speed set incorrectly?

▶ Is there a changeover procedure you have overlooked?

▶ Is the feeder's main air regulator set incorrectly?

Step 2—Inspect Your Product. After checking the feeder, check to see if your product has changed since the last batch:

▶ Are they larger? Smaller? A different shape? A different material? Different color? Different quality?

Continued ▶

- ▶ If you are orienting freshly molded product, have you made a change in how they are released from the mold? (Are they hotter, drier or stickier, for example?)
- ▶ Finally, if your product has changed, or if you cannot isolate why your product is jamming, contact your direct supplier for assistance.

Troubleshooting Charts

Refer to the following pages for troubleshooting charts detailing common problems and the possible solutions (Figures 5-7 & 5-8).

Chart Continued ▶

<i>Problem</i>	<i>Possible Cause</i>	<i>Solution</i>
Rate is too low. Parts exit feeder okay.	Feeder starved.	<i>Correctly set prefeeder rate.</i>
	Rim speed incorrect.	<i>Correctly set rim speed.</i>
Rim or disc does not turn.	Part jammed in feeder.	<i>Disconnect power; locate and remove part; then continue operation.</i>
	Torque limiter loose.	<i>Adjust torque limiter.</i>
Feeder won't run at all.	Power off or disconnected.	<i>Turn on power.</i>
	Downstream machinery is completely full.	<i>Clear downstream machinery.</i>
	Motor controller defective or trim pot settings changed.	<i>Replace motor speed controller & "horsepower" resistor or recalibrate to motor speed controller mfr.'s instructions.</i>
	Defective motor.	<i>Replace motor.</i>
Rim jerks when moving.	Motor controller defective or trim pot settings changed.	<i>Replace motor speed controller or recalibrate to motor speed controller manufacturer's instructions.</i>
	Loose drive chain.	<i>Adjust chain drive tension.</i>
Surface of parts scuffed or dirty.	Particulate in feeder.	<i>Clean rim and disc.</i>
	Parts already scuffed.	<i>Check upstream machinery.</i>

Figure 5-7. FT-40-RD & FT-50-RD Feeder Troubleshooting

Chart Continued ►

<i>Problem</i>	<i>Possible Cause</i>	<i>Solution</i>
Cannot adjust motor speed high enough.	Motor controller defective or trim pot settings changed.	<i>Replace motor speed controller or recalibrate to motor speed controller manufacturer's instructions.</i>
	Motor speeds incorrect.	<i>Correctly set rim speed and prefeeder rate.</i>
Rim and disc turn but parts don't exit properly. Parts jam.	Air off or incorrect.	<i>Check air pressure at main air pressure regulator. Check air flow.</i>
	Incorrect part.	<i>Verify that feeder is correctly set up to run this part.</i>
	Parts are different.	<i>Verify that feeder is tooled to run this part.</i>
	Tooling or air jets need adjustment.	<i>Refer to your System Operations Manual or contact your direct supplier.</i>

Figure 5-8. FT-40-RD & FT-50-RD Feeder Troubleshooting

Replacement Parts

6

Notice to Shibuya Hoppmann Customers:

Replacement part lists for the standard models are stapled in the rear cover of this manual. To ensure receiving the correct replacement part(s) specific to your system, consult your system operations manual.

If you did not receive a Shibuya Hoppmann customized system, or you do not have a copy of the systems operations manual, contact SHC. ***Prior to contacting SHC, copy down the information from your system's serial plate(s).*** This helps eliminate incorrect spare parts, and will assist us in making sure we have the correct parts for your tooled system. See Figure 6-1 for the two types of serial plate's that will be located on your system. ***This information is necessary when ordering replacement parts or service.***

Shibuya Hoppmann Corporation's contact information is listed on the following page.

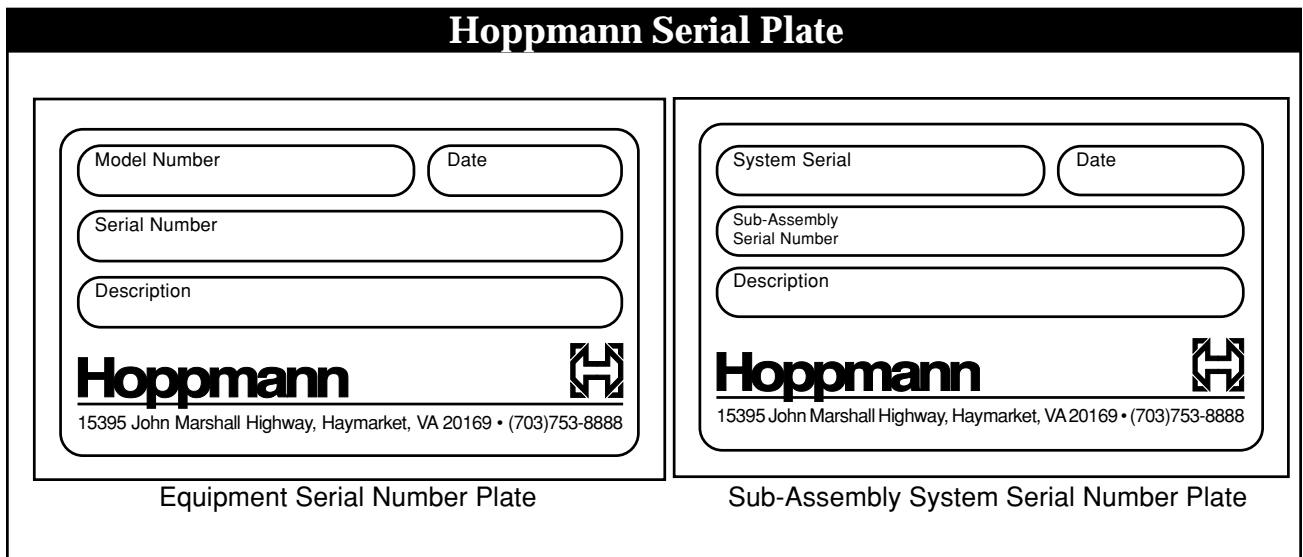

Figure 6-1. Serial Plate Layouts - Equipment and System

Notice to Dealer & OEM Customers:

Some components listed might have been changed by your dealer or OEM to work better with your application. To avoid ordering the wrong replacement part, verify the part number listed in the insert to the back of this manual when you place your order with your dealer or OEM.

Hoppmann Corporation
13129 Airpark Drive, Suite 120
Elkwood, Virginia 22718 USA
Phone: (540) 829-2564 Toll Free: (800) 368-3582
Fax: (540) 829-1724
e-mail: spares@hoppmann.com
website: www.hoppmann.com

Warranty

Hoppmann Corporation warrants that each item of its own manufacture delivered hereunder shall, at the time of delivery and for a period of twelve (12) months thereafter, be free from defects in materials or workmanship; and if any such item shall prove to be defective in material or workmanship under normal intended usage and maintenance during the warranty period, upon examination by Hoppmann Corporation, then Hoppmann Corporation shall repair or replace, at its sole option, such defective item at its own expense; provided, however, that the owner shall be required to ship such defective item, freight prepaid, to Hoppmann Corporation's plant from where it was shipped. The warranty on components not manufactured by Hoppmann Corporation, but a part of the **feeder**, is limited to the warranty provided by the original manufacturer of said components to the extent, and only to the extent, that such original manufacturer actually honors such warranty. **All warranties hereunder are expressly limited to the repair or replacement of defective items as set forth herein, and in no event shall Hoppmann Corporation be liable for special, incidental or consequential damages by reason of any breach of warranty or defect in material or workmanship. Hoppmann Corporation shall not be responsible for repair or replacement of items which have been subjected to neglect, accident or improper use, or which have been altered by other than authorized Hoppmann Corporation personnel.**

This warranty is in lieu of other warranties, express or implied. All implied warranties, including but not limited to the implied warranties of merchantability and fitness for a particular purpose are hereby excluded.

Scheduled Mechanical Maintenance

Once Every 6 Months

- ▶ Clean as needed
- ▶ Change gear oil in ANSI reducer
- ▶ Inspect chain tension
- ▶ Lube Idler Assembly (single drives)

Performed by (initial) _____ (date) _____

Performed by (initial) _____ (date) _____

Performed by (initial) _____ (date) _____

Performed by (initial) _____ (date) _____

Performed by (initial) _____ (date) _____

Performed by (initial) _____ (date) _____

Performed by (initial) _____ (date) _____

Performed by (initial) _____ (date) _____

Performed by (initial) _____ (date) _____

Performed by (initial) _____ (date) _____

Scheduled Electrical Maintenance

Once Every 6 Months

- ▶ Inspect/replace motor brushes

Performed by (initial) _____ (date) _____

Performed by (initial) _____ (date) _____

Performed by (initial) _____ (date) _____

Performed by (initial) _____ (date) _____

Performed by (initial) _____ (date) _____

Performed by (initial) _____ (date) _____

Performed by (initial) _____ (date) _____

Performed by (initial) _____ (date) _____

Performed by (initial) _____ (date) _____

Performed by (initial) _____ (date) _____

Performed by (initial) _____ (date) _____

Maintenance Information - See Chapter 4.