

Model FT-30-RD Centrifugal Feeder

ANSI/Metric Installation & Maintenance Manual

**Refer all servicing to
qualified personnel.**

*This manual is written for qualified
mechanics and electricians
who must install or service the
FT-30-RD Feeder.*



*Please copy this information
from the FT-30-RD
Feeder's serial plate.*

Inventory/Serial Number:

Inventory Number (Check One):

- | | | |
|-------------------------------------|-------------------------------------|-------------------------------------|
| <input type="checkbox"/> FT301RLACA | <input type="checkbox"/> FT301RLDCA | <input type="checkbox"/> FT302RLACA |
| <input type="checkbox"/> FT301RLACM | <input type="checkbox"/> FT301RLDCM | <input type="checkbox"/> FT302RLACM |
| <input type="checkbox"/> FT301RLASA | <input type="checkbox"/> FT301RLDSA | <input type="checkbox"/> FT302RLDCA |

Second Edition, Publication Version, All Rights Reserved.

Copyright © 2002 by Hoppmann Corporation

15395 John Marshall Highway

Haymarket, Virginia 20169

Phone: (703) 753-8888

Toll Free: (800) 368-3582

Fax: (703) 753-7485

www.hoppmann.com • pubs@hoppmann.com





Quick Start

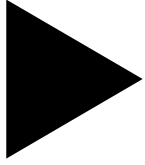

About this Manual

Assumptions

This manual is written for qualified mechanics and electricians who install or service the FT-30-RD Centrifugal Feeder. All procedures in this manual should be performed by qualified personnel.

► References in this manual may not apply to your FT-30-RD feeder. In some cases, your direct supplier may have modified or replaced some of the standard components of the feeder on which these procedures are based. In such cases, you may need to slightly modify these procedures. If you are unsure which standard components of your FT-30-RD feeder (if any) have been changed, consult your direct supplier's documentation.

Models Covered

This manual covers nine models. If you are unsure which model you have, locate the inventory number on the serial plate of the feeder.

<i>Inventory No.</i>	<i>Metric</i>	<i>Inventory No.</i>	<i>ANSI</i>
FT301RLACM	1 AC Motor	FT301RLACA.....	1 AC Motor
FT301RLDCM	1 DC Motor	FT301RLASA	1 AC Motor
FT302RLACM	2 AC Motors	FT301RLDCA.....	1 DC Motor
		FT301RLDSA	1 DC Motor
		FT302RLACA.....	2 AC Motors
		FT302RLDCA.....	2 DC Motors

Caution Symbols & Messages

Caution symbols and messages in this manual call attention to hazardous conditions.



The exclamation point caution symbol denotes possible personal injury and/or damage to the equipment.



The lightning bolt caution symbol denotes possible personal injury and/or damage to the equipment from electrical hazards.

Equipment Improvements & Document Revisions Notice

Hoppmann Corporation continually improves its products, and reserves the right to change or discontinue specifications and designs shown in this manual without notice and without incurring obligation. Hoppmann Corporation has made every effort to verify the information contained in this manual, but reserves the right to correct any error at the time of the manual's next revision.

As-Built Documentation This manual does not contain as-built documentation. As-built documentation is provided by your direct supplier. If you purchased your tooled feeder directly from Hoppmann Corporation, you will automatically receive this information in your System Operations Manual.

Tools You Will Need The FT-30-RD feeders are offered in both ANSI and metric versions. For maximum compatibility, ANSI units are classified as "soft ANSI" construction, meaning that metric threads and hardware are used throughout. Both metric and ANSI units require metric tools for repair or adjustment. If your direct supplier tooled your feeder with (SAE) hardware, you will need standard tools as well.



If the feeder has been tooled by your direct supplier, any part of the feeder that touches your product has been tooled for your product. Avoid making any adjustments to the tooling, moving the tooling could adversely affect the performance of your tooled feeder.



Table of Contents

	Page		Chapter
Quick Start	2	About this Manual	
Feeder Description & Specifications	7	Overview of the FT-30-RD	1
		<i>Figures:</i>	
	6	Figure 1-1. FT-30-RD Feeder (Dual Drive) Overall Exploded View	
	8	Table 1-1. Feeder Specifications (Dual Metric)	
	9	Figure 1-2. Feeder Specifications (Dual Metric)	
	10	Table 1-2. Feeder Specifications (Single & Dual ANSI)	
	11	Figure 1-3. Feeder Specifications (Single & Dual ANSI)	
Safety Precautions	13	Safety Precautions	2
	13	Operating & Maintenance: Do's & Don'ts	
Installation & Startup	15	Included in this Chapter	3
	15	Unpacking, Inspection & Registration	
	15	Physical Setup	
	16	Starting the Feeder for the First Time	
	17	How to Set Proper Bowl Speed	
	18	Running Product for the First Time	
	18	General Tips	
		<i>Figures:</i>	
	17	Figure 3-1. Measuring & Changing Bowl Speed	
	19	Figure 3-2. AC Metric Wiring Diagram (Dual Drive)	
	20	Figure 3-3. DC ANSI Wiring Diagram (Single & Dual Drive)	
Preventive Maintenance	21	General Cleaning	4
	21	Change Gear Oil in ANSI Speed Reducer	
	22	Reducer Seals Replacement	
	23	Chains and Sprockets Lubrication	
	23	Inspect Chain Tension	
	25	Inspect/Replace Motor Brushes	



FT-30-RD Feeder Installation/Maintenance Manual

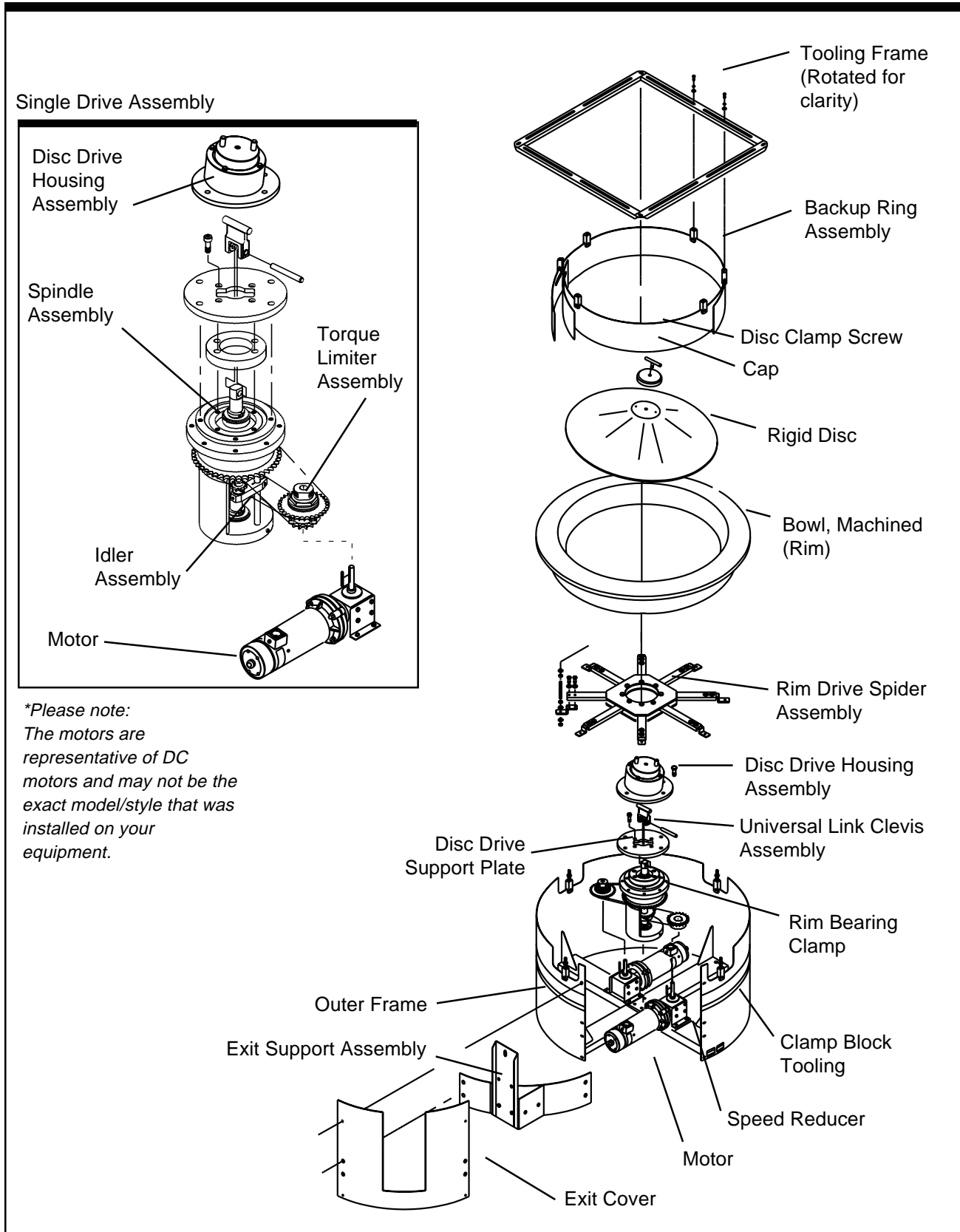

Figure 1-1. FT-30-RD Feeder (Dual Drive) : Overall Exploded View

Feeder Description & Specifications

1

Overview of the FT-30-RD

Thank you for purchasing a Hoppmann Model FT-30-RD Centrifugal Feeder. Hoppmann feeders are easy to use, easy to maintain and easily handles your product quietly and rapidly. The FT-30-RD feeders unscramble, orient and feed product. (Refer to Figure 1-1 for an exploded view of the FT-30-RD feeder).

Function The delivery rate varies depending on product characteristics. The feeder easily interfaces with Hoppmann's prefeeders, accumulating conveyors and assembly equipment. (See to Figure 1-2 and Figure 1-3 for FT-30-RD product specifications.)

Operation **Step 1—The Feeder Accepts Your Product.** Every FT-30-RD feeder accepts product from a separate bulk supply hopper or prefeeder. Product drops randomly, a few at a time, onto a rigid disc.
▶ The FT-30-RD feeders run best when parts are not emptied, in bulk, directly onto the rigid disc, but instead, when parts are carefully metered into the FT-30-RD feeder a few parts at a time. The FT-30-RD feeders deliver parts almost immediately.

Step 2—The Feeder Loads and Qualifies Your Product. Product is metered into the bowl, dropping onto the rigid disc, and loaded onto the rim for singulation and qualification. The rim moves the product past mechanical, pneumatic and/or optical qualifiers. Improperly oriented product is rejected, and returned to the reservoir area of the bowl for recirculation.

Step 3—The Feeder Delivers Your Product. Next, product moves off the rim and out of the FT-30-RD feeders, in proper orientation, for delivery to downstream operations.



FT-30-RD Single Drive Specifications

Specifications - FT-30-RD

Specifications - FT-30-RD	ANSI	Metric
Inventory No.	FT301RLACA FT301RLDSA FT301RLDCA FT301RLASA	FT301RLACM FT301RLDCM

Electrical Specifications

Motor Size	1/3 hp	250 W
Motor Frame Size	NEMA 56C	IEC 71D
Supply Voltage	Refer to Chapter 3 Wiring Diagrams	
Motor Voltage	Refer to Chapter 3 Wiring Diagrams	
Power Usage	5 amps	3 amps

Dimensional Specifications

A. Outer Wall Diameter	40.25"	1022 mm
B. Overall Height	24.00"	610 mm
C. Discharge Height	17.44"	480 mm
D. Bowl Outer Diameter	36.13"	918 mm
E. Bowl Inner Diameter	28.78"	731 mm
F. Rim Width	3.67"	93 mm
G. Bowl Depth	5.65"	180 mm
H. Leveling Feet Height	1.25" ± .50"	32 mm ±13 mm
Disc Diameter*	28.63"	727 mm
Disc - Bowl Gap	.015"	.38 mm
Overall Weight	≈ 350 lbs.	≈ 159 kg

Performance Specifications

**Maximum Bowl Linear Speed (@Rim ID)	300 feet/minute	90 meters/minute
Vertical Bowl Runout (Max.)	0.010"	0.254 mm
Vertical Disc Runout (Max.)	0.125"	3.175 mm



* *The disc diameter is based on the standard urethane bowl. If an upgraded Aluminum bowl was purchased, the disc diameter is 28.5". If an oversized bowl was purchased, the disc diameter is 28.75".*

** *Maximum speed is not the operating speed, it's provided as a reference value only.*

Table 1-1. FT-30-RD Feeder Specifications (Single Motor)

FT-30-RD Single Drive Specifications

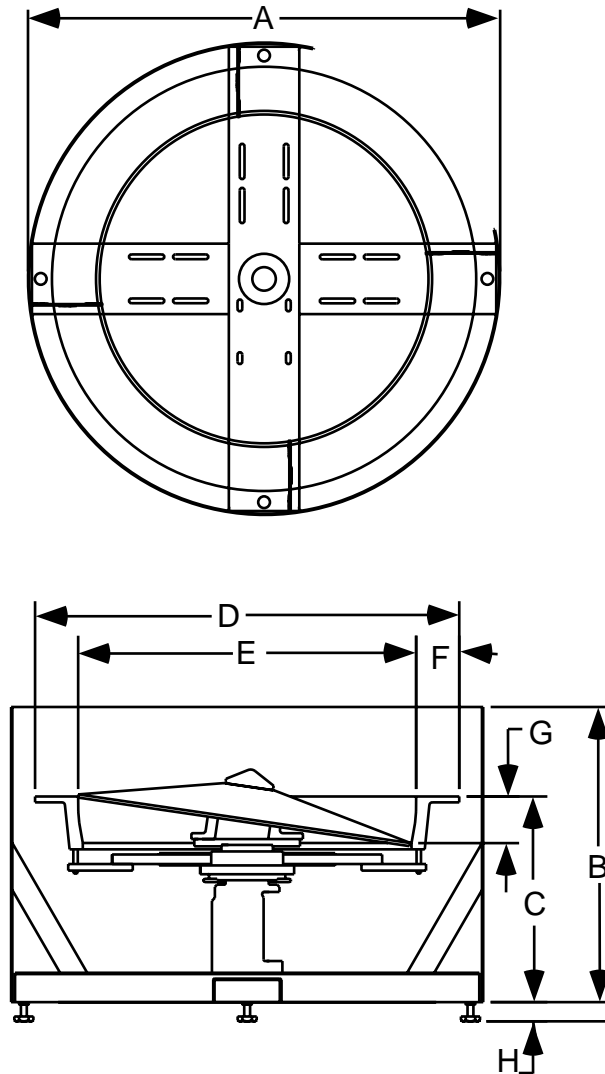

Your direct supplier may have changed some of these specifications during tooling to better match your application's requirements.

Figure 1-2. FT-30-RD Feeder Specifications (Single Motor)



FT-30-RD Dual Drive Specifications

Specifications - FT-30-RD	ANSI	Metric
Inventory No.	FT302RLACA FT302RLDCA	FT302RLACM

Electrical Specifications

Motor Size - Bowl Drive Motor	1/3 hp	250 W
Motor Size - Disc Drive Motor	1/3 hp	250 W
Motor Frame Size	NEMA 56C	IEC 71D
Supply Voltage	Refer to Chapter 3 Wiring Diagrams	
Motor Voltage	Refer to Chapter 3 Wiring Diagrams	
Power Usage	5 amps	3 amps

Dimensional Specifications

A. Outer Wall Diameter	40.25"	1022 mm
B. Overall Height	24.00"	610 mm
C. Discharge Height	17.44"	480 mm
D. Bowl Outer Diameter	36.13"	918 mm
E. Bowl Inner Diameter	28.78"	731 mm
F. Rim Width	3.67"	93 mm
G. Bowl Depth	5.65"	180 mm
H. Leveling Feet Height	1.25" ± .50"	32 mm ±13 mm
Disc Diameter*	28.63"	727 mm
Disc - Bowl Gap	.015"	.38 mm
Overall Weight	≈ 395 lbs	≈ 180 kg

Performance Specifications

**Maximum Bowl Linear Speed (@Rim ID)	300 feet/minute	90 meters/minute
Vertical Bowl Runout (Max.)	0.010"	0.254 mm
Vertical Disc Runout (Max.)	0.125"	3.175 mm



* The disc diameter is based on the standard urethane bowl. If an upgraded Aluminum bowl was purchased, the disc diameter is 28.5". If an oversized bowl was purchased, the disc diameter is 28.75".

** Maximum speed is not the operating speed, it's provided as a reference value only.

Table 1-2. FT-30-RD Feeder Specifications (Dual Motors)

FT-30-RD Dual Drive Specifications

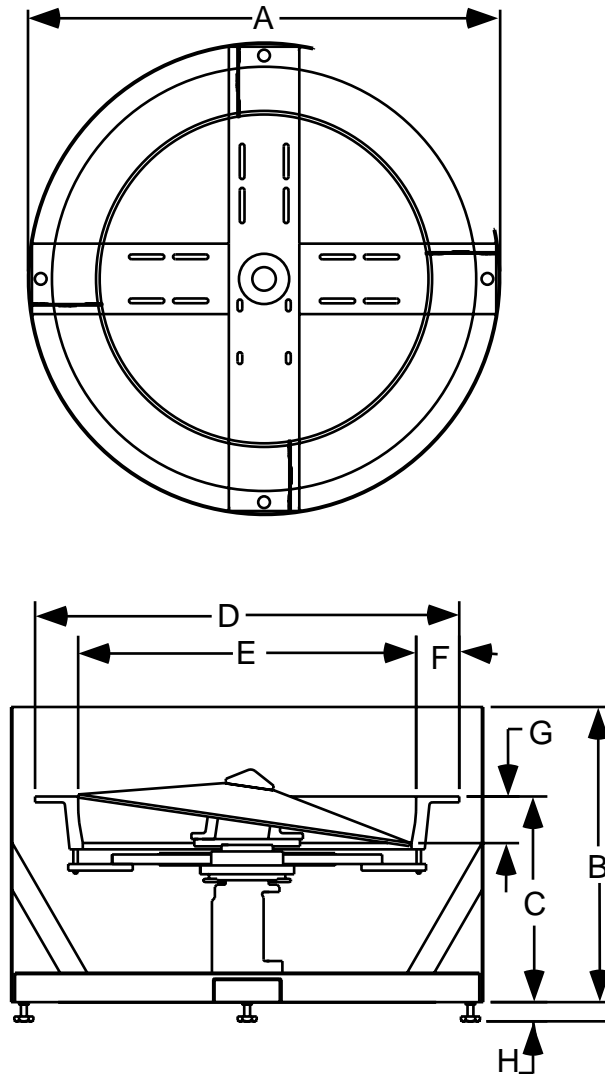

Your direct supplier may have changed some of these specifications during tooling to better match your application's requirements.

Figure 1-3. FT-30-RD Feeder Specifications (Dual Motors)



Notes

Safety Precautions

2

Safety Precautions



Turn Off Power! Before servicing, make sure you have turned off compressed air and electrical power in a way which prevents accidental reactivation. Padlock and clearly tag the appropriate electrical and pneumatic disconnects. Lockout/tagout procedures are covered in United States Code of Federal Regulation (CFR) Title 29 Part 1910.147, "The Control of Hazardous Energy."



Dress Appropriately! Reduce the risk of injury from moving parts by securing loose sleeves and other clothing. Do not wear loose jewelry or neckties near the feeder. Wear safety glasses or other protective eyewear when servicing the feeder. Never place hands or tools in the feeder when it is operating.



Install Safety Guards! Make sure the feeder remains safe to operate. Be sure all safety guards have been installed before returning the feeder to normal operation. Safety guards on the FT-30-RD Feeder include any guards (which protect the operator from the moving bowl spider, sprockets and chains).



Secure Safety Covers! Before feeder operation, secure all safety covers. Most safety covers are electrically interlocked, and will prevent the machine operation if disengaged.

Operating & Maintenance: Do's & Don'ts

Don't Give the Feeder Too Much Product. Do not overfill the feeder, because it may jam or lose rate. Bulk product should be metered into the feeder. Allow only enough product into the feeder to keep the line running at the required rate.

Don't Run the Feeder Too Fast. Do not run the bowl faster than the linear feet per minute recommended by your direct supplier. If you do, the orientation qualifiers can not do their job as efficiently, and the feeder may jam or lose rate.



Don't Adjust Air Jet Flow Controls. It is okay to adjust the main air regulator to its correct setting for your installation. However, air jets and their individual flow controls have all been carefully preset to work with your product; they should never need adjustment. If you move air jets or adjust their individual flow controls, the feeder may jam or lose rate.

Do Perform Preventive Maintenance. To keep the feeder running without unexpected repairs and resulting downtime, regularly perform the preventive maintenance procedures in Chapter 4.



Do Carefully Replace Any Tooling You Remove. To gain access for repairs, you may need to remove tooling. Because Hoppmann and your dealer or OEM have no control over such activities, they can not be responsible for any tooling you remove. **Carefully document the position of any tooling before you begin.** If you fail to replace all tooling exactly as it was, you may create difficult and time consuming problems.

Don't Operate the Feeder Near Flammable Gas, Vapor or Dust. Do not install a feeder in these conditions unless you install additional, approved explosion-proof or dust ignition-proof enclosures. Without such additional enclosures, normal sparking of the brushes inside the motor could ignite flammable gas, vapor or dust.

Do Replace Failed Bearings in the Spindle Assembly. The spindle assembly should only be taken apart to replace a failed bearing. Follow the procedures in Chapter 5 for bearing replacement.

Installation & Startup

3

Included in this Chapter

Follow, in order, each section of this chapter to install any fully tooled FT-30-RD feeder. For your convenience, *Tables 1-1, 1-2, 1-3, 1-4, 3-2 and 3-3*, show electrical specifications for your feeder and suggested wiring.

Unpacking, Inspection & Registration



Step 1—Inspect and Unpack the Crate. Remove packing materials from sensors, tooling and moving parts. Make a visual check to be sure parts have not come loose during shipping. If you find any concealed damage, call the shipping carrier and your direct supplier immediately. ***Do not attempt to fix the problem yourself unless told to do so by your direct supplier.***

Step 2—Record Serial Numbers. For future reference and assistance in ordering parts, record on the front of this manual the feeder's model and serial number (see Figure 6-1).

Physical Setup

You should refer to as-built drawings (not part of this manual) for electrical, pneumatic and equipment layout specifications.

Step 1—Position the Feeder. Place the feeder as shown on the equipment layout drawing provided by your direct supplier.

Step 2—Level the Feeder. Level the machine by adjusting the leveling feet. Tighten the locknuts on the leveling feet.

Step 3—Connect the Output Device. Check that product can move smoothly from the exit of the feeder to your output device (deadplate, conveyor, gravity track or powered rollers, for example). Check that product will not jam or lose their orientation as they move to the output device.

Continued ►



Step 4—Position the Prefeeder. Now place your bulk supply hopper, or prefeeder, into position. Follow the equipment layout drawing provided by your direct supplier, or the feeder may not operate correctly. *If you are providing and integrating a prefeeder, continue reading the step below. If your direct supplier is providing and integrating both your feeder and prefeeder, skip to Step 5.*

If you are supplying your own prefeeder, you are responsible for:

- ▶ Providing and installing the feeder's bowl level switch so it can control the flow of your prefeeder.
- ▶ Setting the timing delay for the feeder's bowl level switch.
- ▶ Correctly positioning the prefeeder. Generally, the prefeeder should discharge product to fall on the rigid disc, halfway between the center of the bowl and the outside diameter. Take a handful of product and drop them from the chute of your prefeeder into the feeder. Avoid dropping product so that it bounces up off the rigid disc onto the rim of the bowl, which could knock off product that are already loaded. You may need to position the prefeeder again, if necessary, once the feeder is running.

Step 5—Connect Electrical Supply and Air. Connect your feeder to electrical supply and compressed air (if applicable).

Starting the Feeder for the First Time

Step 1—Secure Safety Covers. Before turning on power and air, make sure safety covers are in place and that you are dressed appropriately for safety.

Step 2—Check for Rubbing Parts. Turn the feeder bowl by hand. In the unlikely event that you hear any unusual noises, discontinue immediately and check in and around the bowl for any foreign objects causing the noise (for example, check between the backup ring and the rim of the bowl.)

Step 3—Turn on Power and Air. Turn on the feeder's power. If applicable, turn on the feeder's main air regulator.

How to Set Proper Bowl Speed

Ask your direct supplier for the actual speed at which the bowl should rotate. For reliability, set the bowl to match that speed.

► You will need a hand-held tachometer (analog or digital) with a surface speed wheel indicator (see Figure 3-1).

► This procedure is performed with power on and the feeder operating. If your direct supplier has installed a cover over the bowl, you will need to open it before proceeding.

Step 1—Turn on Feeder. Turn on the feeder and run it without product.

Step 2—Set Bowl Speed. To set bowl speed, place hand-held tachometer (with surface speed indicator attachment) on the inner wall of the moving bowl, at its most upper inside diameter. Adjust bowl speed until bowl is moving at correct number of linear feet per minute (FPM).

► If you have only one drive motor installed (standard) you can ignore the rigid disc speed, which changes proportionally as the bowl speed changes.

Continued ►

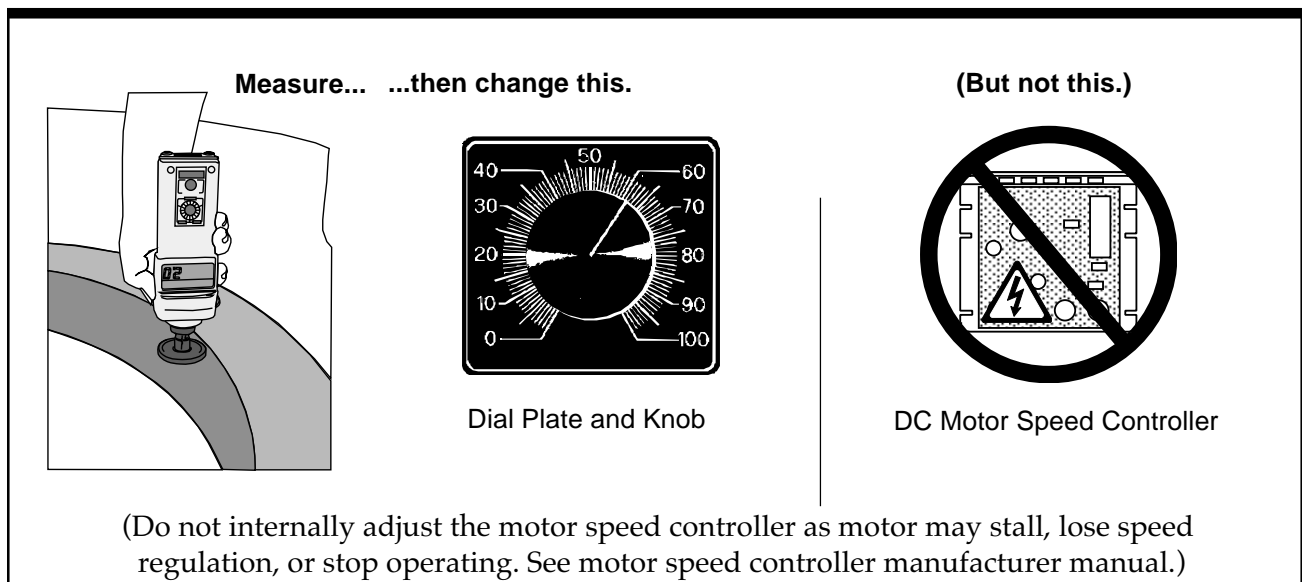

Figure 3-1. Measuring and Changing Bowl Speed



► If your feeder has dual drive motors installed, after you complete the procedure to set the bowl speed (see previous step), measure the disc speed in RPM at the center of the disc using your hand held tachometer with the appropriate attachments.

Step 3—Record New Settings. Turn off the feeder. Mark dial plate with new setting and remove any old marks.

Running Product for the First Time

Step 1—Verify Changeover Setup. If your feeder is tooled to run multiple parts, ensure the feeder is set up for the product you want to run.

Step 2—Inspect Product at Exit. Inspect the exit of the feeder. If product is exiting the feeder properly oriented, at the required rate and without jamming, then installation is complete. Otherwise, continue with Step 3. Do not adjust the flow controls on any air jet.

Step 3—Verify Prefeeder Speed. Normally this step is completed by your direct supplier. However, if you are separately providing and integrating the prefeeder, you will have to set the prefeeder's speed. To do this, turn the prefeeder's speed control all the way down, then turn on the feeder.

► Slowly (you may need to take several minutes) raise the prefeeder's speed control until enough parts exit, the feeder to keep the line running at the required rate.

► Note: ***Excessive prefeeder output may overload the feeder and reduce its output.***



General Tips

► After your feeder is set up and running, observe the flow of product at each transition point. Later, if a problem occurs, observe these transition points to help pinpoint the cause.

► Listen to the way the feeder sounds when it is running properly. If it suddenly sounds different, investigate why.

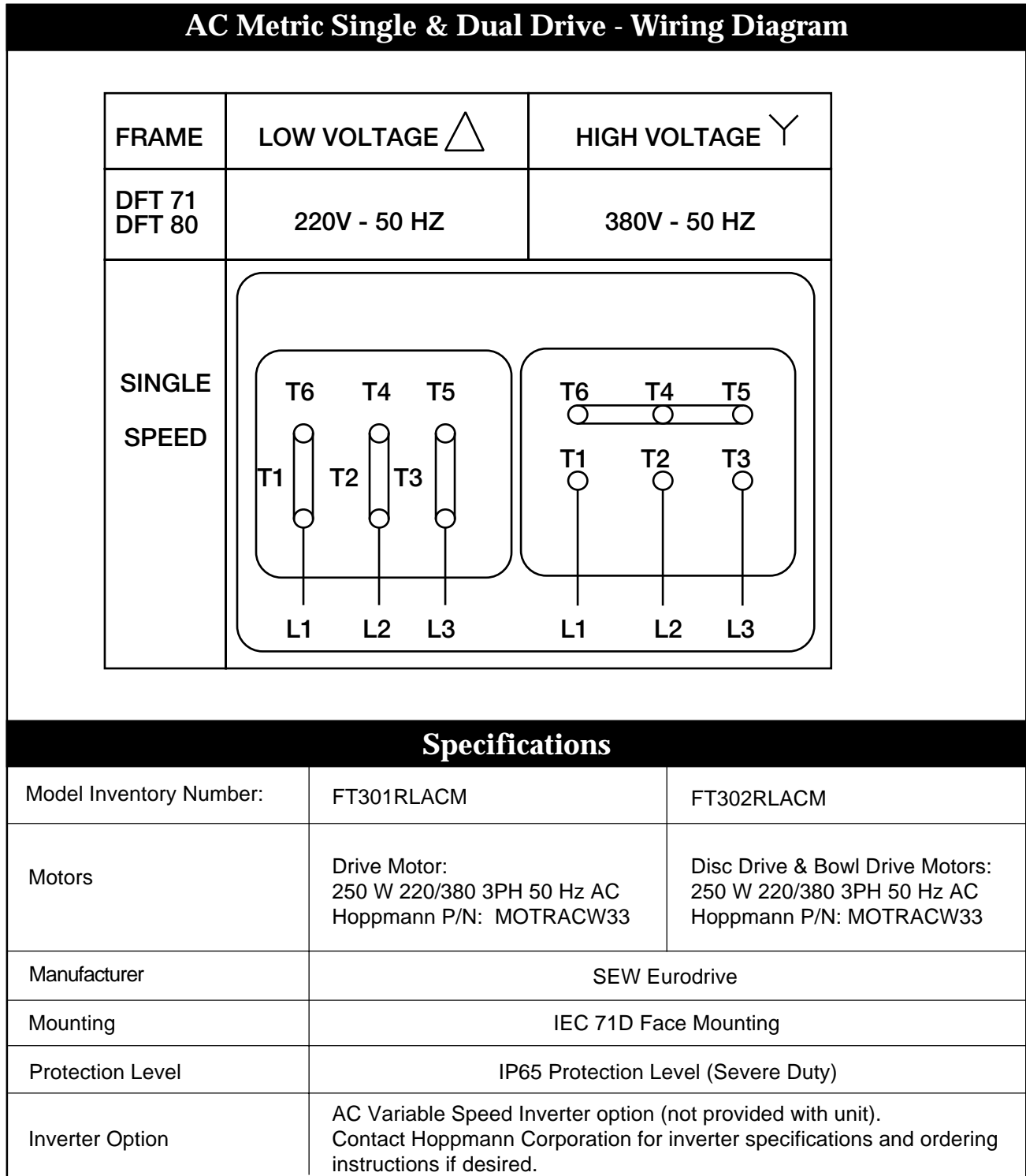

Figure 3-2. FT-30-RD AC Metric Wiring Diagram (Single & Dual Drives)

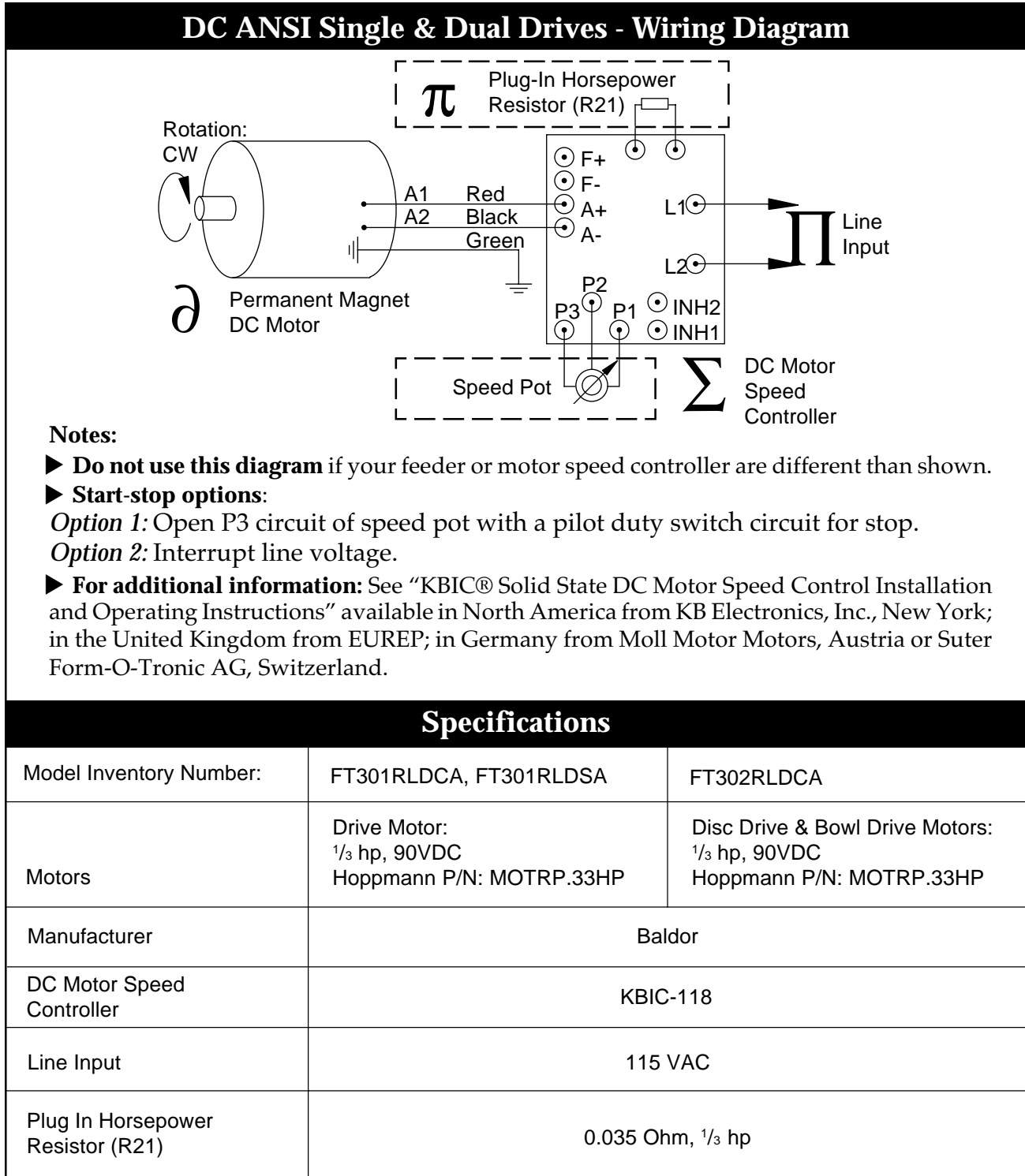

Figure 3-3. FT-30-RD DC ANSI Wiring Diagram (Single & Dual Drive)

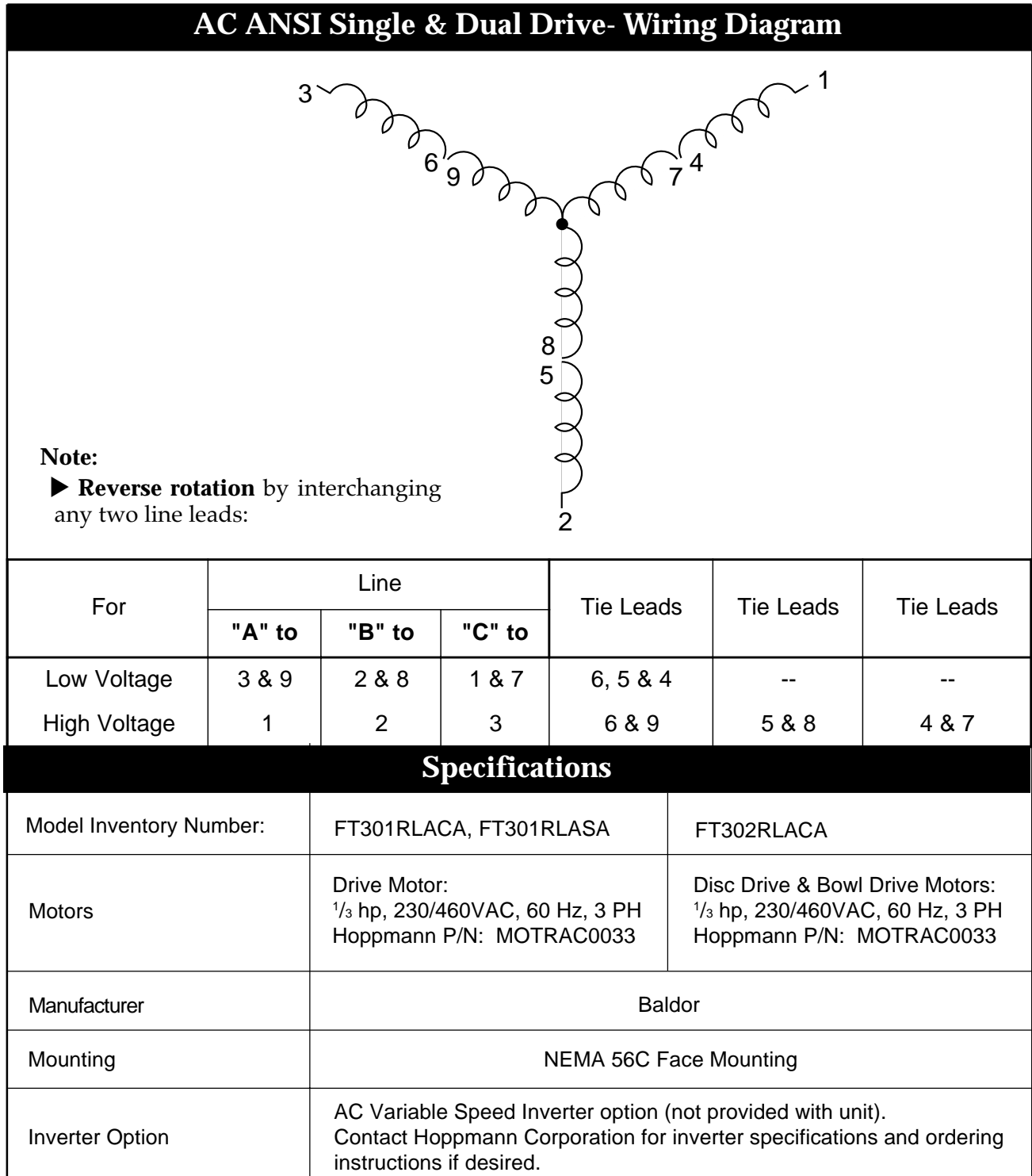

Figure 3-4. FT-30-RD AC ANSI Wiring Diagram (Single & Dual Drive)

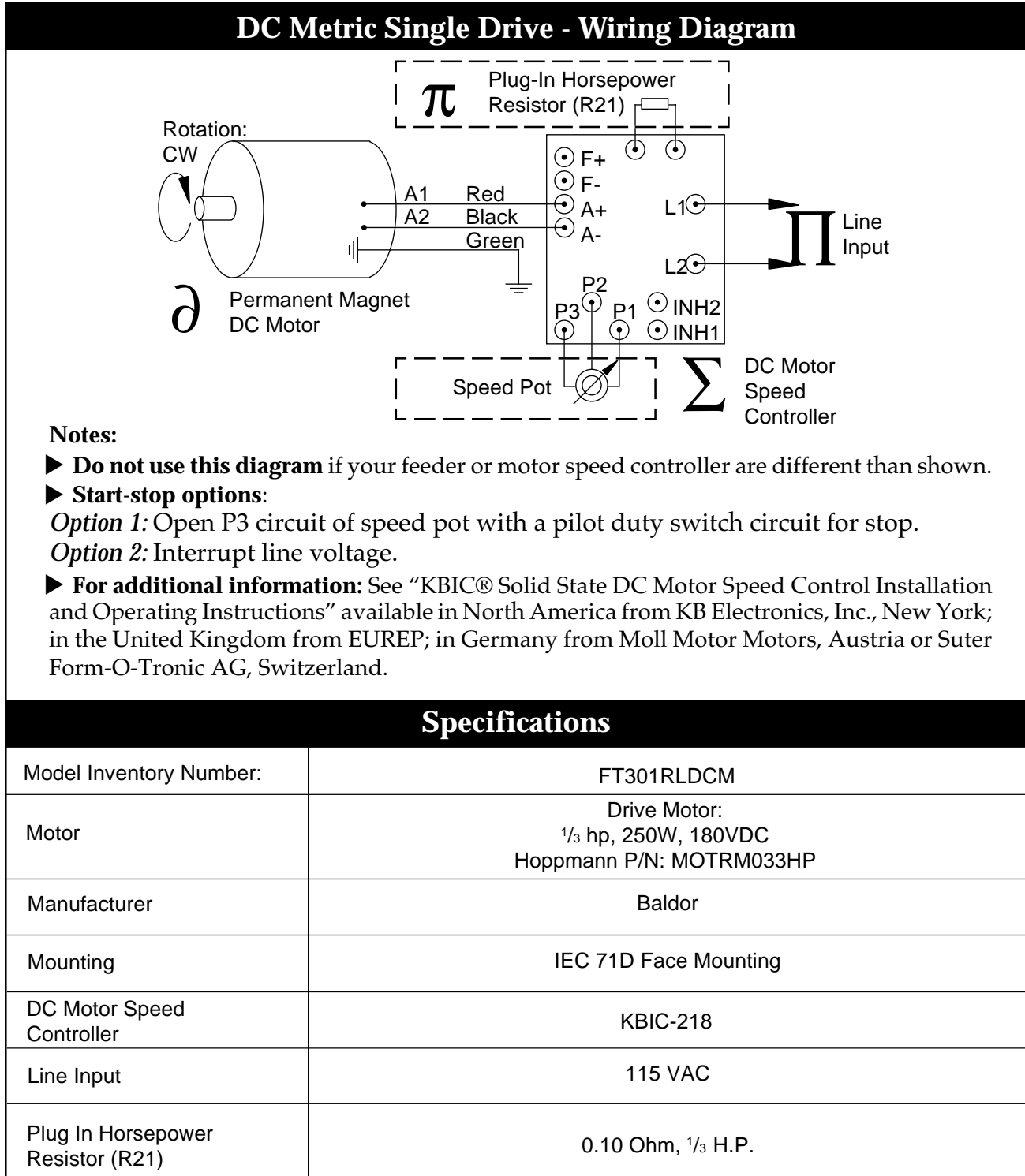

Figure 3-3. FT-30-RD DC Metric Wiring Diagram (Single Drive)

Preventive Maintenance

4

General Cleaning

Outer Frame & Tooling

The Hoppmann Model FT-30-RD Centrifugal Feeder is **not** intended for washdown use. If you need to clean the **outer frame**, the **rim of the bowl**, the **rigid disc** or **tooling**, use mild household cleaners.

"Dusty" Applications

If your parts generate dust or particulate when handled, you'll need to clean the feeder as often as necessary. For such parts, remove the dust from the top surface of the rim of the bowl and the disc with a portable vacuum cleaner or dry compressed air.

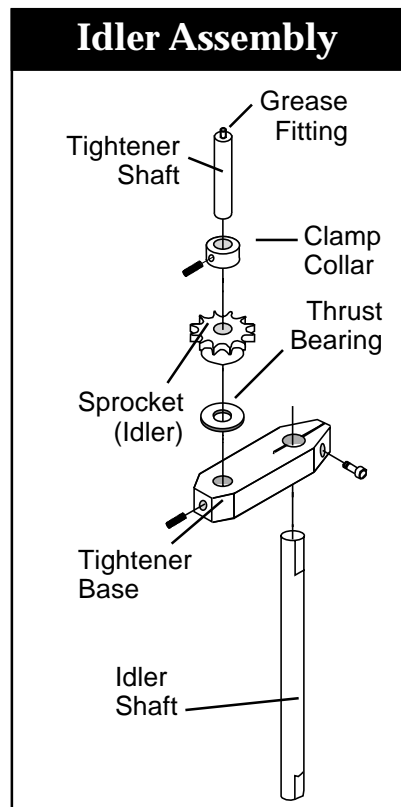

Figure 4-1.
Idler Assembly

Idler Assembly Maintenance

It is recommended you grease the idler assembly, for both the metric and ANSI single drive models, every six (6) months after installation. Note the order of assembly (see Figure 4-1).

Gear Oil in ANSI Speed Reducer

The speed reducer comes with factory installed synthetic lubricants.



The manufacturer recommends that you change the gear oil every two years or 6000 operating hours, whichever comes first.

▶ The speed reducer in the ANSIFT-30-RD feeder requires periodic maintenance; the speed reducer in the metric FT-30-RD feeder does not.

▶ You may need to change the gear oil more often if you run the FT-30-RD feeder in a room which is unusually hot or dirty.

▶ Check the level of gear oil before draining (see Figure 4-2). If the level is low, check the reducer's input and output shaft seals for leaks.

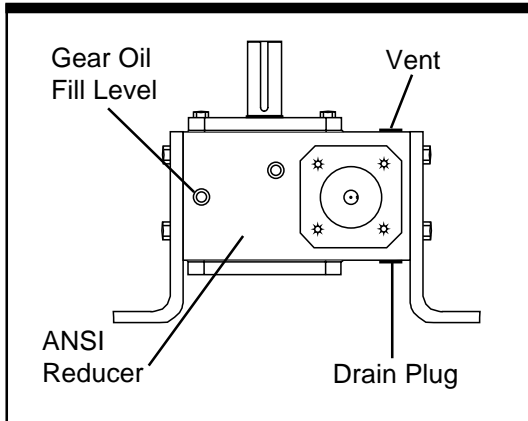

Figure 4-2. Gear Oil Fill Level

- ▶ Drain the gear oil while warm; the gear oil will drain more easily than if cold. If there are any metal contaminants, they are less likely to remain behind.
- ▶ Refill to the correct level with the recommended gear oils (see Table 4-1). The gear oils shown are specifically for the worm gear speed reducer in the ANSI FT-30-RD feeder; other gear reducers may require different types of gear oil.

Tip: The ANSI FT-30-RD feeder is shipped to your direct supplier with synthetic gear oil. Because synthetic gear oil has increased resistance to heat and oxidation, it does not have to be changed as often as conventional gear oil.

Metric Speed Reducer—No Lubrication Required. The metric speed reducer used in the metric FT-30-RD feeder are lubricated for life with synthetic lubricant and require no regular lubrication or venting.

Speed Reducer Gear Oil FT-30-RD Centrifugal Feeders - ANSI Only	
<i>Recommended Gear Oil or Equivalent</i>	Mobil "SHC 634 Synthetic"
<i>Ambient (Room) Temperature</i>	-30 to +125° (-34 to +52° C)
<i>Viscosity Range SUS at 100° F.</i>	1950 / 2150
<i>AGMA No.</i>	*
<i>ISO*** Viscosity Grade</i>	320/460
<p><small>* Mobil SHC 634 is the only synthetic gear oil we recommend. ** Ask for equivalent gear oil by AGMA number from most major oil companies. *** International Organization For Standardization, Switzerland</small></p>	

Table 4-1. Recommended Gear Oil

Continued ▶

Reducer Seals Replacement

The speed reducer uses seals which may need to be replaced. Follow the steps below to replace the seals on the reducer:

Step 1—Remove the Worn Seal. Remove the worn seal without damaging the shaft surface of the seal bore. This can be done by drilling a .062 diameter hole in the seal casing (being careful not to drill into the bearing behind the seal). Screw a #10 sheet metal screw into the hole and pry out the seal.

Step 2—Clean the Seal Bore of Sealant.

Step 3—Cover Keyways. Before installing the new seal, use electrical tape to cover any keyways on the shaft to prevent seal lip damage.

Step 4—Grease Seal Lips. Grease the seal lips with bearing grease, and apply a sealant to the seal bore.

Step 5—Replace Seal. Slide the seal into the shaft being careful not to fold the inner lip over on any shaft steps.

Step 6—Press Seal into Bore. Press the seal into its bore with a sleeve that presses on the seal casing, being careful to keep the seal square in its bore.

Chains and Sprocket Lubrication

On all FT-30-RD feeders, grease the disc and rim drive chains and sprockets every six months, or every 1000 operating hours, whichever comes first.

▶ Before beginning, disconnect power and air. Remove the exit cover and exit support assembly to gain access to the feeder. Lock and tag out the feeder.

▶ Use standard Moly grease, Lubriplate #3000 (NLGI Grade 2) or the equivalent. Turn the bowl by hand to expose all the links of the bowl drive chains.

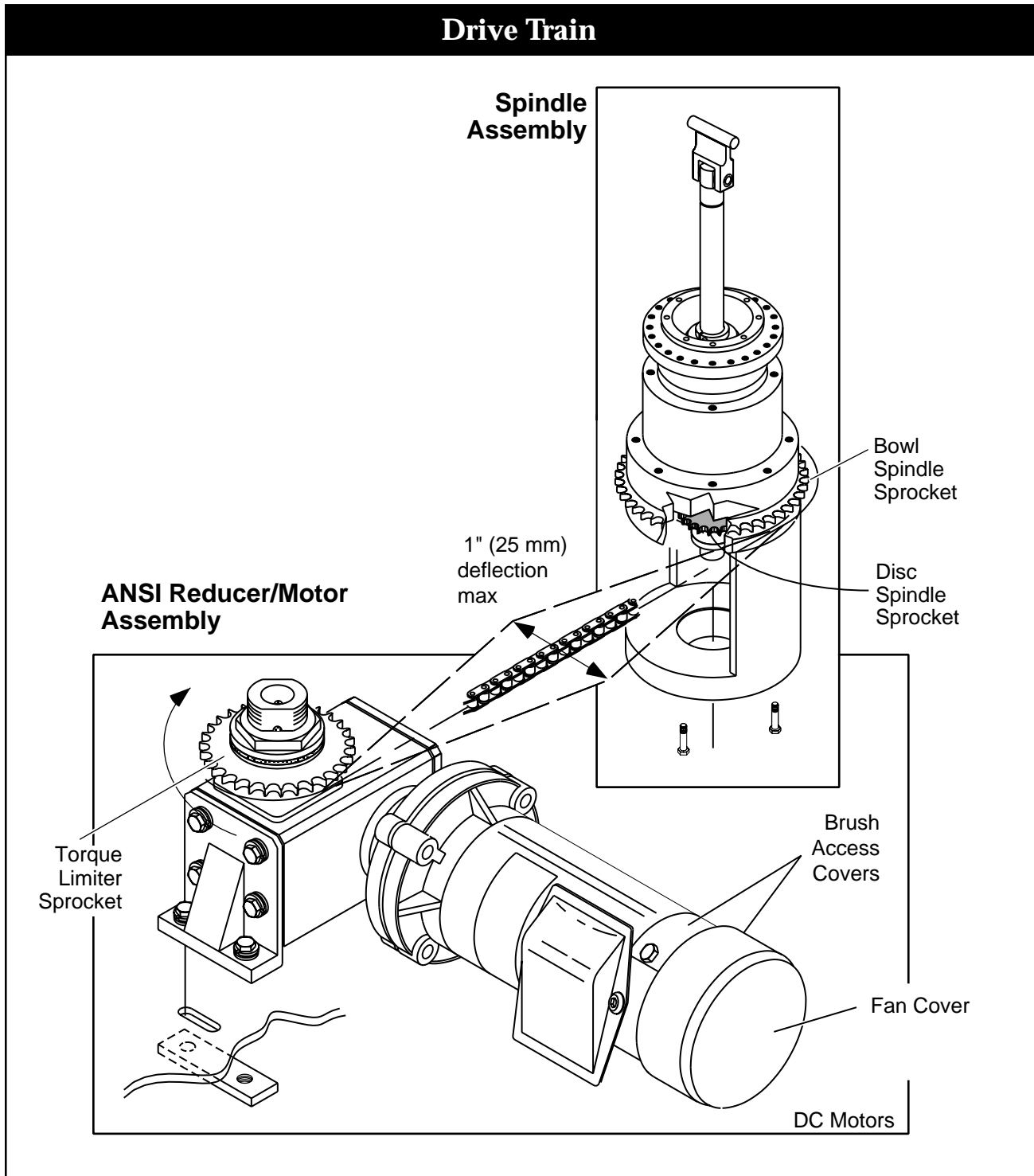

Figure 4-3. FT-30-RD Drive Train (DC Motor)

Inspect Chain Tension

Step 1—Gain Access. Improper chain tension wears out sprockets and chains. When lubricating or performing other maintenance tasks, inspect the tension of the chain. If you have not already done so, disconnect power and air, and remove the exit cover and the exit support assembly to gain access.

Step 2—Inspect Drive Chain. Midway between the sprockets, grasp the chain and move it back and forth. You should not be able to move it more than 1" in either direction. If it moves more than 1", adjustment is required (see Figure 4-3.) If adjustment is needed:

▶ For single drive feeders: Loosen the idler, adjust the motor and retension the idler.

▶ For dual drive feeders: Adjust the motor/reducer mounting plate for each motor by moving the reducer back and forth as necessary.

Step 3—Check for Parallel Sprockets. Check that each set of sprockets is parallel to within $1/32$ " (0.8 mm). If not parallel, realign to within the above specification.

Step 4—Replace Guards and Covers. Replace guards and covers and connect power and air. Initial and date the Maintenance Log in the back page of this manual.

Inspect/Replace Motor Brushes



The following procedure applies only to DC motors and should be performed only by qualified personnel.

Step 1—Gain Access. Disconnect power and air. Remove feeder guards and covers as needed to gain access to the motor. Then remove the motor brush access covers.

Continued ▶



Step 2—Clean the Motor. Clean the motor by blowing into the open access hole with compressed air.

Step 3—Replace Brushes. Lift the brush spring from the end of the brush (see Figure 4-4). Remove the brush connector, withdraw the brush and inspect the length. To prevent motor damage, brushes should be replaced when or before they reach a length of 0.575" (15 mm). New brush length is 1.03" (26 mm). Reverse procedure to replace brush. Replace motor access and feeder covers. Connect power and air. Initial and date the Maintenance Log.

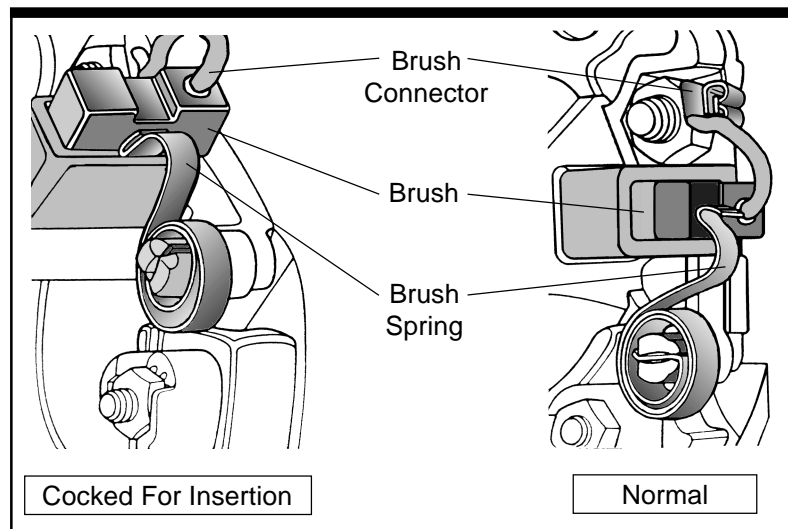

**Figure 4-4. DC Motor Brushes
(Gasketed Cover Removed)**

Repair & Troubleshooting

5

Torque Limiter: Adjustment/Replacement

The torque limiter allows the drive sprocket to slip harmlessly in the event of a product jam. Severe humidity or dryness, lubricants or surface corrosion on bushings or the drive sprocket may reduce the effectiveness of the torque limiter. The torque limiter should be inspected and adjusted if the rim is free wheeling.

Step 1—Disconnect power. Turn off power and air.

Step 2—Gain Access. Remove exit cover and rim drive chain.

Step 3—Remove Torque Limiter. Remove and disassemble torque limiter. (See Figure 5-1) Inspect and replace any broken or worn parts. Observe order of components.

Step 4—Assemble Torque Limiter. Clean parts before re-assembly. Assemble the torque limiter. Tighten adjusting nut hand tight. Do not completely flatten the disk spring.

Step 5—Install Torque Limiter. Install the torque limiter. Tighten the adjusting nut (see Figure 5-1) down until the bowl turns when power is applied with minimum slippage. Do not completely flatten the disk spring. Also do not lock the adjusting nut yet. You will lock the adjusting nut after turning on the motor. Some slippage must occur to prevent damage, however, there should be no slippage if the bowl is at maximum rotation.

Step 6—Replace Chain. Replace chain and inspect chain tension (refer to Figure 4-3).

Step 7—Lock Adjusting Nut. Lock the adjusting nut by bending a lockwasher tab over it. Make sure any safety covers you removed have been replaced. The FT-30-RD feeder is ready for use.



Note: *Some slippage must occur to prevent damage, however, there should be no slippage if the bowl is at maximum rotation.*

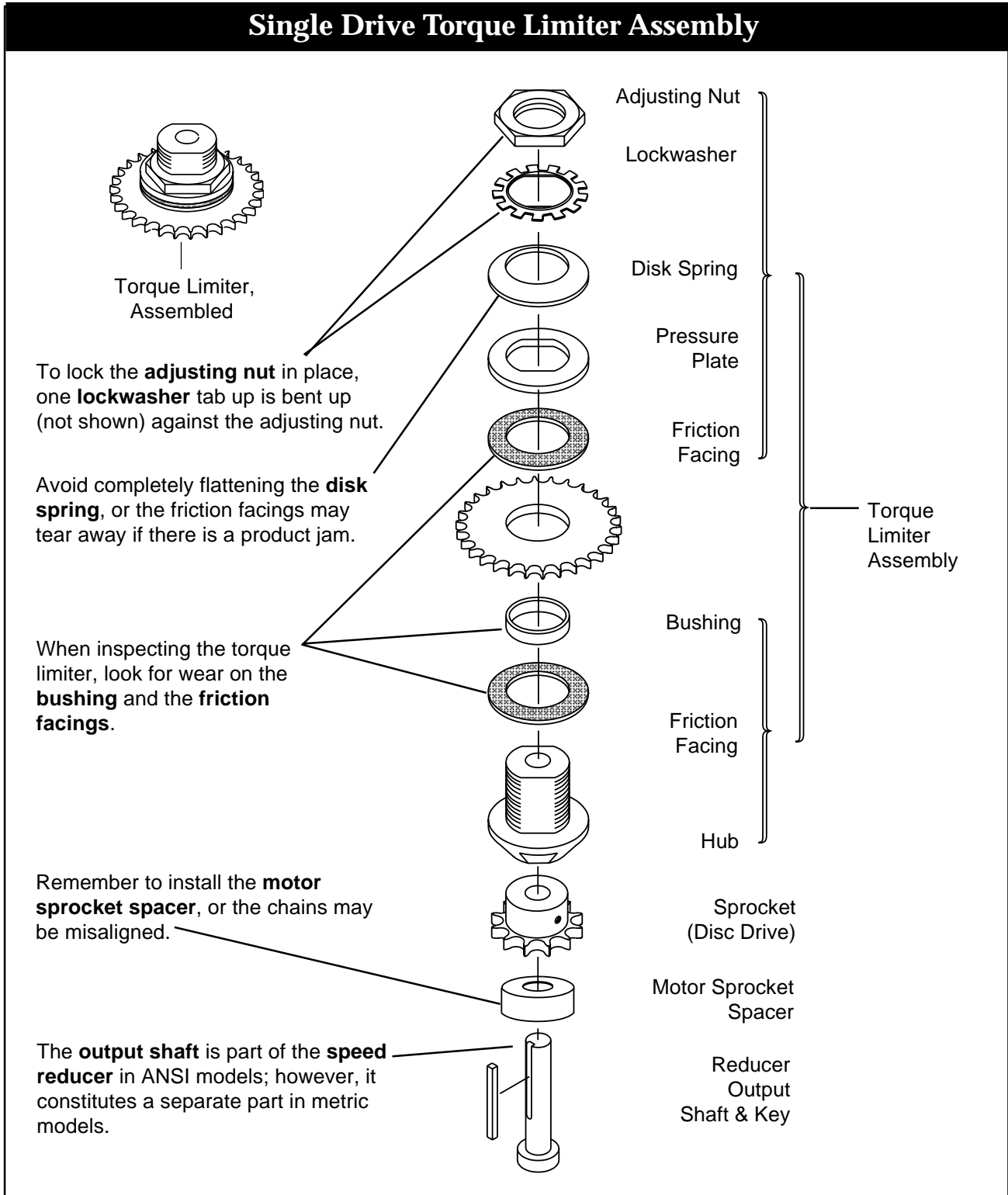

Figure 5-1. Torque Limiter Assemblies

Replacing a Standard Bowl

If the standard polyurethane foam bowl becomes damaged in a way that adversely affects the feeder performance the bowl must be replaced.

► Before beginning, remove the prefeeder, the tooling and the disc of the feeder bowl.

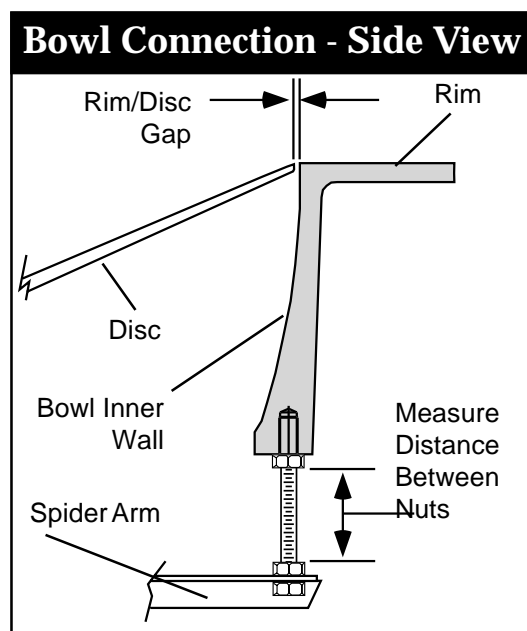

Figure 5-2. Bowl Connection

Step 1—Measuring and Removing the Bowl. Measure the height between the bottom of the bowl, and the top of the spider arm (where the threaded rod connects the two parts - see Figure 5-2). Loosen and remove the bottom nut on the spider arm (on each of the eight (8) arms) and remove the bowl - pulling it up and away from the feeder.

Step 2—Replacing the Bowl. Put the new or refinished bowl in place, then set it to the correct height, $\pm 0.03''$ (0.8 mm) as you measured in Step 1.

Step 3—Bowl Runout. Refer to the section, "To Set Bowl Runout."

Step 4—Replace Disc and Check Covers. Replace the feeder disc and make sure all covers are in place before running the feeder.

Upgraded Aluminum Bowl Only

If you have purchased an upgraded Aluminum Bowl with your feeder and the bowl becomes damaged in a way that adversely affects the feeder performance, the bowl may be refinished. (*Follow **Steps 1 - 4** above to replace the refinished bowl.)

► If the damage is slight, recoating with commercial hard coat by a professional metal refinisher may correct the problem.

► Machining must be done in such a way that bowl runout is restored to original tolerances, or the feeder may not operate correctly.

► If machining enlarges the inner diameter of the bowl, you may need to replace the disc with a larger one (custom-sized) from your direct supplier. If you do not obtain a larger disc, the gap between the disc and the inner diameter of the bowl may pinch or snag product (see Figure 5-2).



Chain Drive Nomenclature - Single Drive

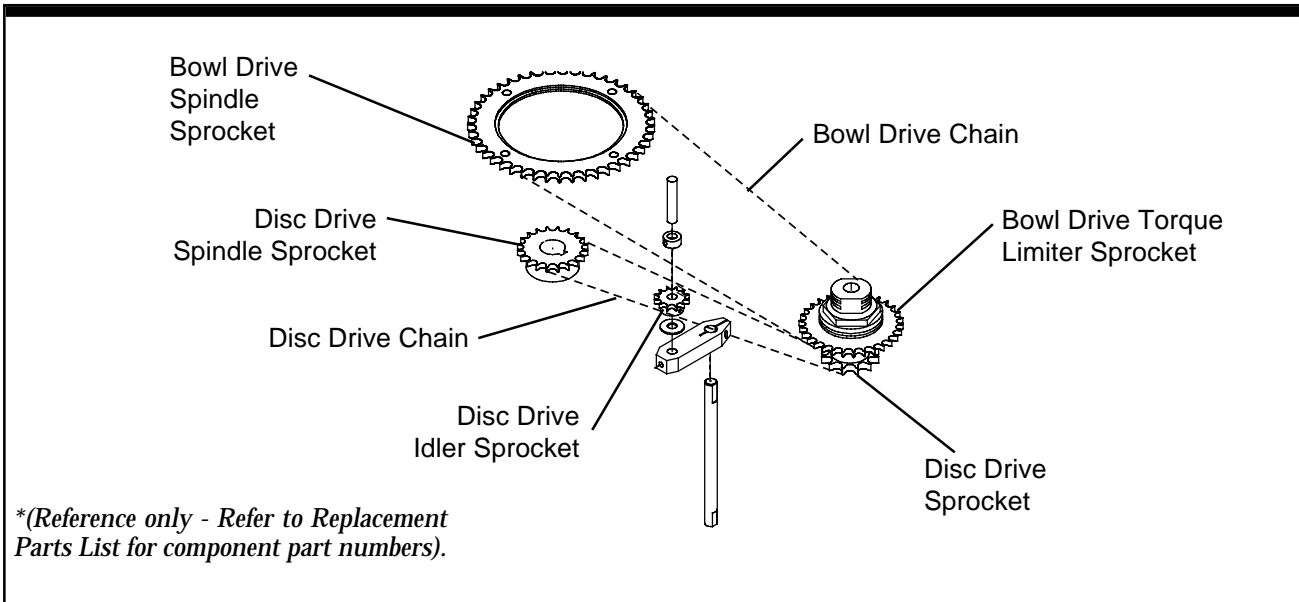

Figure 5-3. Single Drive Sprocket Location Diagram

Inventory No.'s: **FT301RLDCA – FT301RLACA – FT301RLASA – FT301RLDSA – FT301RLDCM**

Sprocket Name/Location	# of Teeth
Bowl Drive Sprocket	45 Teeth
Bowl Drive Torque Limiter Sprocket...	30 Teeth
Disc Drive Spindle Sprocket.....	20 Teeth
Disc Drive Idler Sprocket.....	12 Teeth
Disc Drive Sprocket.....	18 Teeth
Chain Lengths	
Bowl Drive Chain	#40 x 33.5" Long
Disc Drive Chain	#40 x 24.5" Long

Inventory No.'s: **FT301RLACM**

Sprocket Name/Location	# of Teeth
Bowl Drive Sprocket	45 Teeth
Bowl Drive Torque Limiter Sprocket...	30 Teeth
Disc Drive Spindle Sprocket.....	20 Teeth
Disc Drive Sprocket.....	18 Teeth
Chain Lengths	
Bowl Drive Chain	#40 x 34.5" Long
Disc Drive Chain	#40 x 25.5" Long

Chain Drive Nomenclature - Dual Drive

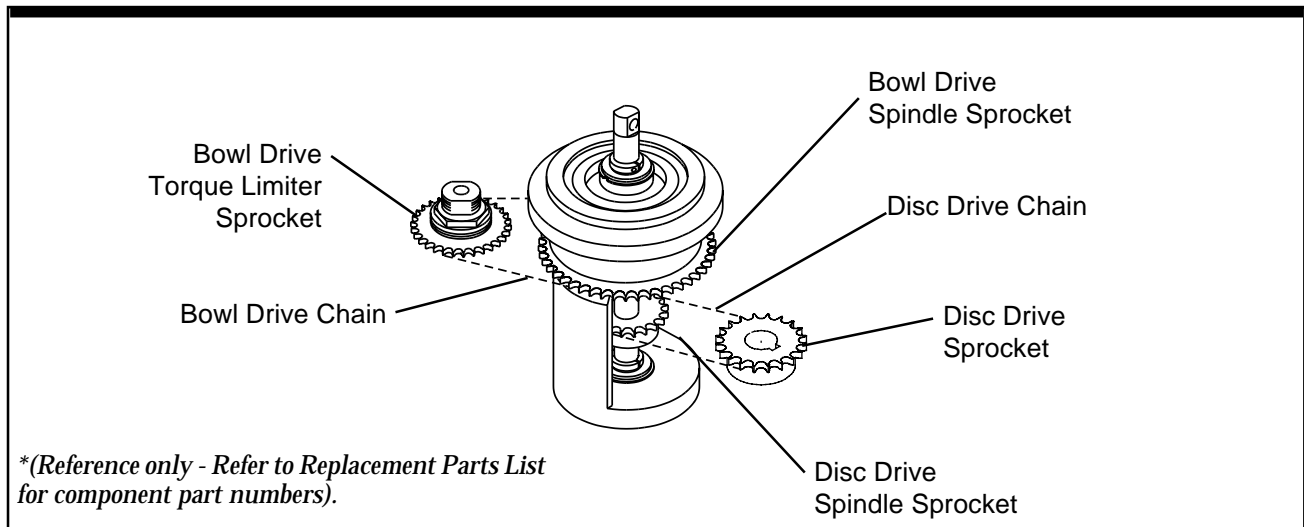

Figure 5-4. Dual Drive Sprocket Location Diagram

Inventory No.'s: FT302RLACA– FT30RLDCA

Sprocket Name/Location # of Teeth

- Bowl Drive Sprocket 45 Teeth
- Bowl Drive Torque Limiter Sprocket... 30 Teeth
- Disc Drive Spindle Sprocket..... 20 Teeth
- Disc Drive Sprocket..... 18 Teeth

Chain Lengths

- Bowl Drive Chain..... #40 x 33.5" Long
- Disc Drive Chain #40 x 24.5" Long

Inventory No.'s: FT302RLACM

Sprocket Name/Location # of Teeth

- Bowl Drive Sprocket 45 Teeth
- Bowl Drive Torque Limiter Sprocket... 30 Teeth
- Disc Drive Spindle Sprocket..... 20 Teeth
- Disc Drive Sprocket..... 18 Teeth

Chain Lengths

- Bowl Drive Chain..... #40 x 34.5" Long
- Disc Drive Chain #40 x 25.5" Long



How to Set Bowl Runout

Bowl runout needs to be reset if the bowl has been removed. Adjust runout with power off and bowl drive chain disengaged.

Step 1—Gain Access. Disconnect power and air. Remove any frame covers.

Step 2—Remove Bowl Drive Chain. Remove the master link. Disconnect the bowl drive chain from the bowl spindle sprocket.

Step 3—Adjust Vertical Runout. Attach a dial indicator to the inside of any upper frame support. Set the indicator contact point vertical on the rim of the bowl, up to $\frac{1}{4}$ " (6 mm) from the bowl's upper inside diameter (ID). Loosen jam nuts and locknuts above and below each arm of the bowl spider one arm at a time. Repeat as often as necessary while checking runout. Do not tighten jam nuts until Step 4.

Step 4—Adjust Horizontal Runout. Move the indicator contact point horizontal on the rim of the bowl, up to $\frac{1}{4}$ " (6 mm) from the bowl's upper ID. Gently tap the bowl's ID with the palm of your hand or a rubber mallet. Tighten locknuts and jam nuts by hand firmly but not forcibly. Inspect vertical runout and adjust again if necessary. Continue alternating between horizontal and vertical runout until both are within specification.

Step 5—Check Exit. Ensure that proper relationship still exists at transition between rim of bowl and output device (deadplate, conveyor, gravity track, or powered rollers, etc.).

Step 6—Check Backup Ring Clearance. Ensure that proper, as-tooled gap still exists between bottom of backup ring and rim of the bowl. (Feeders for most products are tooled with approximately $\frac{1}{8}$ " gap, but for some small products the gap is less; consult your as-built documentation for specifications.) At the upper frame support, adjust the tooling ring up or down, if necessary.

Step 7—Replace Chain & Covers. Install bowl drive chain. Inspect chain tension (see Figure 4-3). Replace covers and reconnect power and air.

ANSI Speed Reducer: Replacement

Follow these instructions to replace the ANSI speed reducer with its direct replacement.

Step 1—Gain Access. Disconnect power and air. Remove the exit cover.

Step 2—Remove Motor. Remove mounting bolts and then remove motor from the speed reducer, leaving wiring intact. Set motor safely aside in a secure position.

Step 3—Remove Old Speed Reducer. Remove the two mounting bolts on each nut plate at the bottom of the reducer mounting brackets. Slide the speed reducer towards the center of the FT-30-RD feeder, and remove the chain. Completely remove the speed reducer assembly.

Step 4—Reducer Installation. Remove the torque limiter and reducer mounting brackets from the old reducer and install them on the new reducer. Slide the torque limiter assembly down onto the reducer output shaft until it bottoms out against the roll pin (see Figure 5-1). Tighten setscrew.

Step 5—Check and Install Gear Oil. Unpack the new speed reducer. Leave rubber sleeves on shafts to protect your hands from any sharp edges on the keyways. Fill the new speed reducer to the correct level with gear oil (unless the reducer is filled by the manufacturer.) Keep the speed reducer level as you install it, or the vent hole may leak (see Figure 4-2). Recommended gear oil is listed in Chapter 4.



Step 6—Install New Speed Reducer. Install new reducer assembly back into the feeder and reattach the two nut plates, securing the assembly to the frame. ***Do not tighten the bolts yet.***

Continued ►



FT-30-RD ANSI Speed Reducer & Motor Assembly

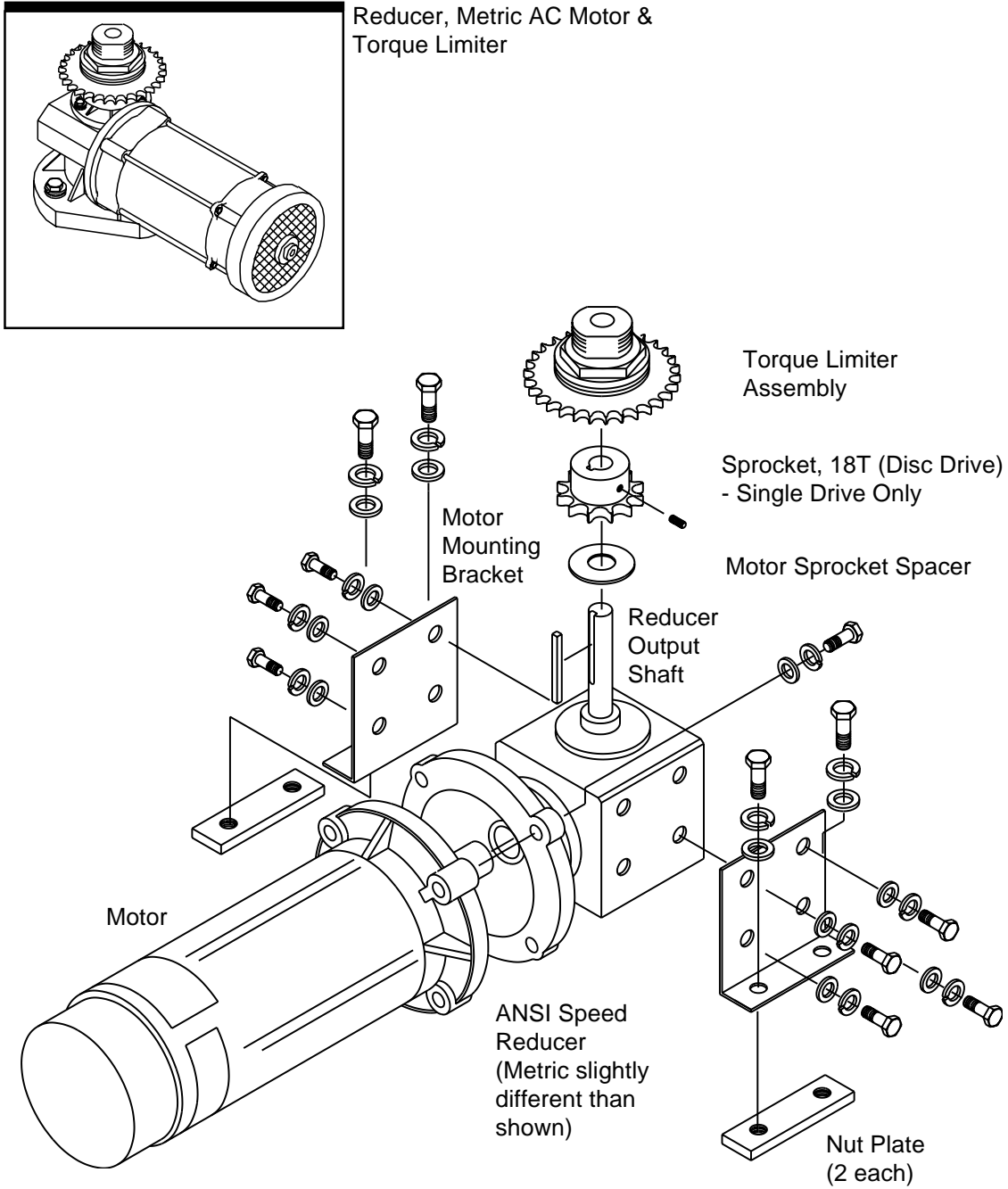

Figure 5-5. FT-30-RD Feeder Speed Reducer & Motor

Step 7—Install Motor. Place the key to the motor shaft and coat the shaft with anti-seize compound. Insert the motor shaft into the speed reducer. Do not allow the motor to "hang" unsupported before fully seated in the reducer to avoid damaging the reducer input seal. Rotate the motor to the correct position and firmly secure to flange with four hex-head cap screws. If the motor does not readily seat itself, check to see if the key has moved.

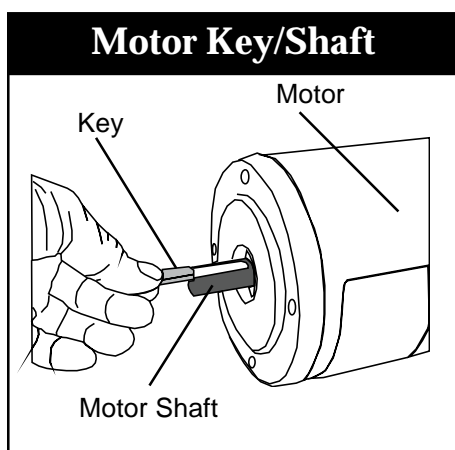

Figure 5-6. Motor Key/Shaft



Step 8—Adjust. Reattach drive chain and re-tension, checking sprocket alignments and wiring to insure no damage has occurred. Tighten the nut plate bolts to the frame.

Step 9—Inspect After Installation. During the speed reducer's break-in period, it may run hotter than normal. **Nevertheless, for maximum life, do not allow the speed reducer to operate continuously above 225°F at the gear case (for AC motors used in Europe, it is customary to use 60°C maximum).** In the event of overheating, check for overloads or high ambient temperatures. Keep shafts and vent plugs clean to prevent foreign particles from entering the speed reducer. Periodically inspect all bolts to make sure they are not loose.

Metric Speed Reducer: Replacement

Follow these instructions to replace the metric speed reducer with its direct replacement.

Step 1—Gain Access. Disconnect power and air. Remove the exit cover.

Step 2—Remove Motor. Remove mounting bolts and then remove motor from the speed reducer, leaving wiring intact. Set motor safely aside in a secure position.

Continued ►



Step 3—Remove Old Speed Reducer. Remove the two mounting bolts on each nut plate at the bottom of the reducer mounting brackets. Slide the speed reducer towards the center of the FT-30-RD feeder, and remove the chain. Completely remove the speed reducer assembly.

Step 4—Reducer Installation. Remove the torque limiter and reducer mounting bracket from the old reducer and install on the new reducer.

Step 5—Assemble Output Shaft. Unlike the ANSI speed reducer, which includes an integral output shaft, the output shaft on the metric speed reducer comes as a separate kit. If replacement is required, clean both contact surfaces before assembly and apply any appropriate anti-seize compound to avoid oxidation (rust) and possible seizing of parts. Slide the torque limiter assembly down onto the reducer output shaft until it bottoms out against the roll pin (see Figure 5-1). Tighten setscrew. The speed reducer used in the metric FT-30-RD feeder is lubricated for life with synthetic lubricant and requires no filling before use.



Step 6—Install New Speed Reducer. Install new reducer assembly back into the feeder and reattach the two nut plates, securing the assembly to the frame. ***Do not tighten the bolts yet.*** Assemble the key to the motor shaft and coat the shaft with anti-seize compound.

Step 7—Install Motor. Install the key to the motor shaft and coat the shaft with anti-seize compound. Insert the motor shaft into the speed reducer. Rotate the motor to the correct position and firmly secure to flange with four hex-head cap screws. Do not allow the motor to "hang" unsupported before fully seated in the reducer to avoid damaging the reducer input seal. If the motor does not readily seat itself, check to see if the key has moved.

Step 8—Adjust. Reattach drive chain and re-tension, checking sprocket alignments and wiring to insure no damage has occurred. Tighten the nut plate bolts to the frame.

Step 9—Inspect After Installation. During the speed reducer's break-in period, it may run hotter than normal. ***Nevertheless, for maximum life, do not allow the speed reducer to operate continu-***



ously above 225°F at the gear case (for AC motors used in Europe, it is customary to use 60°C maximum). In the event of overheating, check for overloads or high ambient temperatures. Keep shafts and vent plugs clean to prevent foreign particles from entering the speed reducer. Periodically inspect all bolts to make sure they are not loose.

Major Bearing Replacement

Major bearings in the FT-30-RD feeder are the upper and lower disc shaft spindle bearings, the upper and lower rim support spindle bearings and the disc support bearing (see Figures 5-7, 5-8 and 5-9). All major bearings except the disc shaft spindle bearings are identical.

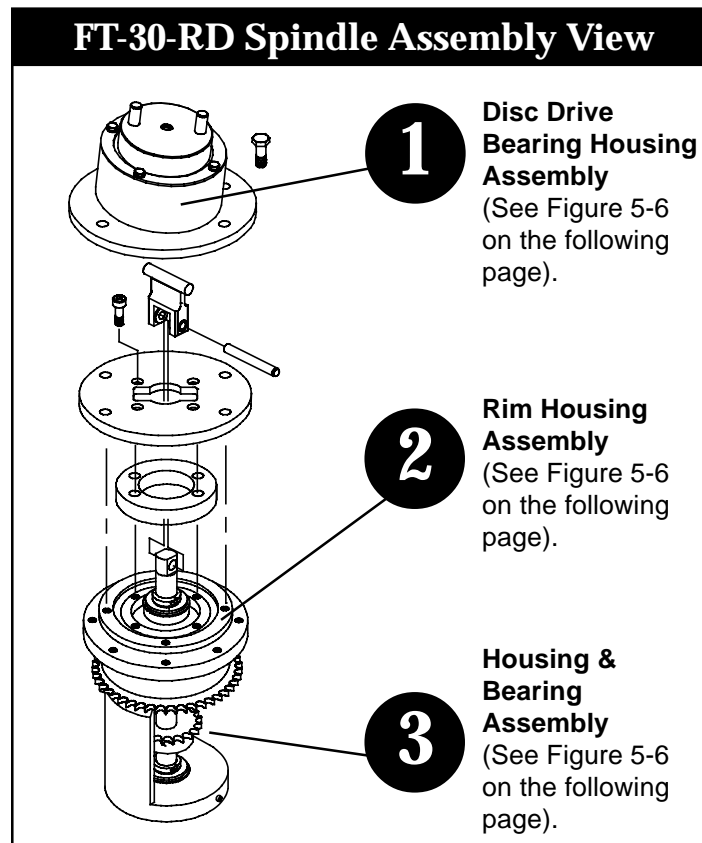

Figure 5-7. FT-30-RD Spindle Assembly



Major Bearing Replacement Cautions:

▶ Eliminate other possible problems before attempting bearing replacement, as substantial disassembly of the feeder is required.

Carefully note position of any tooling you remove before you begin. Keep chains clean and dry after removal.

▶ Most major bearings in the FT-30-RD are preloaded to prevent play. To prevent binding or excessive free play in the bowl, ensure that all bearing housings and the bearings themselves are clean and free of external grease, dirt, nicks or burrs prior to reassembly. If you accidentally damage critical surfaces of the housings, you may need to replace the entire spindle assembly as a unit.

▶ Install only 100% identical replacement bearings. In the unlikely event that the bowl will not turn, or that there is play in the bowl when you are done, you may need to replace the spindle assembly as a unit, or contact Hoppmann Corporation for assistance.

▶ To maintain accuracy and prevent play in the bowl, replace both bearings of a pair at the same time. Do not replace only one.

▶ Do not swap housings (such as the disc shaft spindle bearing housing) from one FT feeder to another, as critical surfaces may have been custom-machined for zero play in the bowl.

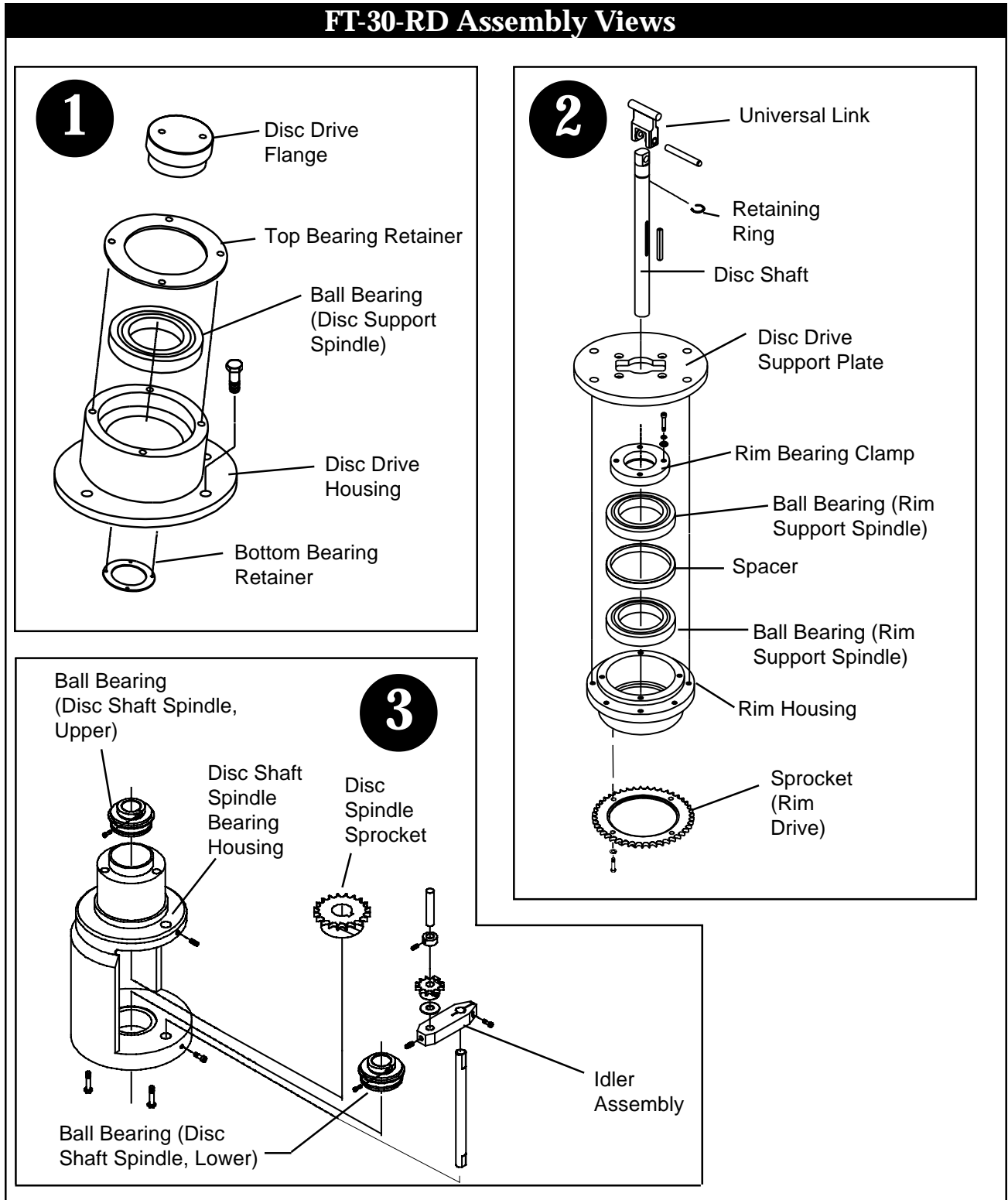

Figure 5-8. FT-30-RD Sectional Spindle Assembly (Single Drive) – Exploded Views

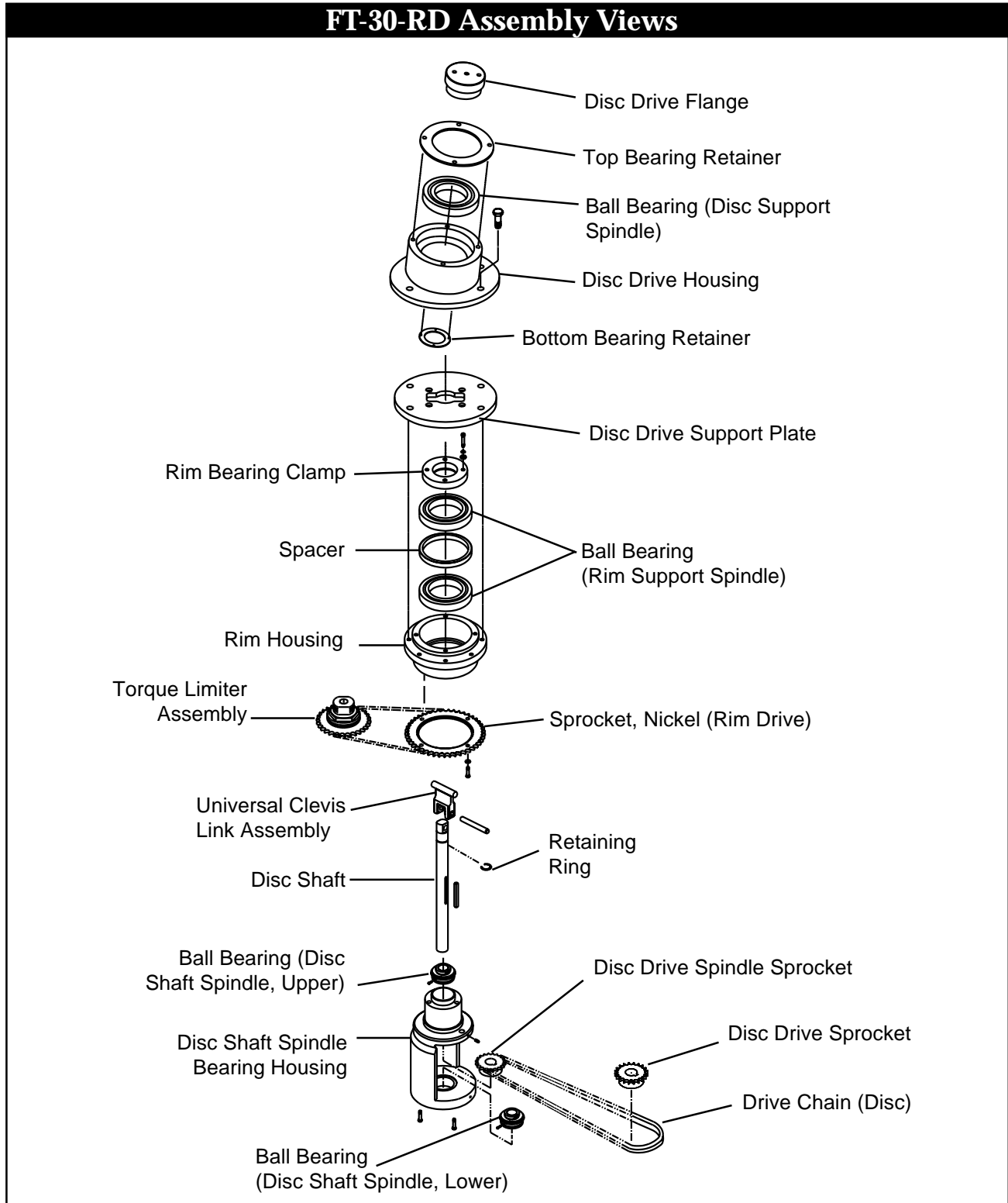

Figure 5-9. FT-30-RD Spindle Assembly - Exploded Views (Dual Drive)

If Product Jams: General Tips

Step 1—Inspect The Feeder. If product jams repeatedly, review the following:

- ▶ Is the prefeeder delivery rate excessive? (The prefeeder should deliver only enough product to the feeder to keep the line running at the required rate.)
- ▶ Is the feeder's bowl speed set incorrectly?
- ▶ Is there a changeover procedure you have overlooked?
- ▶ Is the feeder's main air regulator set incorrectly?

Step 2—Inspect Your Product. After checking the feeder, check to see if your product has changed since the last batch:

- ▶ Are they larger? Smaller? A different shape? A different material? Different color? Different quality?
- ▶ If you are orienting freshly molded product, have you made a change in how they are released from the mold? (Are they hotter, drier or stickier, for example?)
- ▶ Finally, if your product has changed, or if you cannot isolate why your product is jamming, contact your direct supplier for assistance.

Troubleshooting Charts

Refer to the following pages for troubleshooting charts detailing common problems and the possible solutions.



Troubleshooting Charts

Problem	Possible Cause	Solution
<i>Rate is too low - Parts exit the feeder ok.</i>	Feeder is starved for parts.	Correctly set prefeeder rate. Make sure there are sufficient parts in the prefeeder hopper.
	Feeder rim speed is incorrect.	Correctly set rim speed.
<i>Feeder rim or disc does not turn.</i>	Parts jammed in the feeder.	Disconnect power. Locate and remove the jammed part(s). Restart the feeder.
	The torque limiter is loose.	Adjust the torque limiter (refer to Chapter 5).
<i>Feeder won't run at all.</i>	Power is off or disconnected.	Turn on power or reconnect power to the feeder.
	Downstream machinery is completely full.	Clear downstream machinery.
	Motor controller is defective.	Replace the motor speed controller and the horsepower resistor.
	Trim pot settings have changed.	Recalibrate to the motor speed controller manufacturer's specifications.
	Motor is defective.	Replace the motor.
<i>Surface of the parts are scuffed up or dirty.</i>	Particulate (dust, dirt) is in the feeder.	Clean the rim and the disc.
	Parts are already scuffed.	Check upstream machinery.
<i>Rim jerks when moving.</i>	Motor controller is defective.	Replace the motor speed controller and the horsepower resistor.
	Trim pot settings have changed.	Recalibrate to the motor speed controller manufacturer's specifications.
	The drive chain is loose.	Adjust the drive chain tension. Refer to Chapter 4.

Figure 5-10. FT-30-RD Feeder Troubleshooting

Chart Continued ►

<i>Problem</i>	<i>Possible Cause</i>	<i>Solution</i>
<i>Rim and disc turn, but parts don't exit properly. Parts continue to jam.</i>	The motor speeds are incorrectly set.	Correctly set the rim speed and prefeeder rate. Make sure there are sufficient parts in the prefeeder hopper.
	The air is off.	Check air pressure at the main air pressure regulator. Turn on the air.
	The air is incorrectly set.	Check air pressure at the main air pressure regulator. Check to make certain the correct flow is set. Adjust as needed.
	Incorrect parts are being run.	Verify that the feeder is correctly set up to run this part.
	Parts are different.	Check to make sure the feeder is tooled to run this part.
	Tooling or air jets need adjustment.	Refer to your System Operations Manual (supplied separately) or contact your direct supplier.
<i>Cannot adjust the motor speed high enough.</i>	Motor controller is defective.	Replace the motor speed controller and the horsepower resistor.
	Trim pot settings have changed.	Recalibrate to the motor speed controller manufacturer's specifications.
	The drive chain is loose.	Adjust the drive chain tension. Refer to Chapter 4.

Figure 5-10. FT-30-RD Feeder Troubleshooting



Notes

Replacement Parts

6

Notice to Hoppmann Customers:

Replacement part lists for the standard models are stapled in the rear cover of this manual. To ensure receiving the correct replacement part(s) specific to your system, consult your system operations manual.

If you did not receive a Hoppmann customized system, or you do not have a copy of the systems operations manual, contact Hoppmann Corporation. **Prior to contacting Hoppmann, copy down the information from your system's serial plate(s).** This helps eliminate incorrect spare parts, and will assist us in making sure we have the correct parts for your tooled system. See Figure 6-1 for the two types of serial plate's that will be located on your system. **This information is necessary when ordering replacement parts or service.**

Hoppmann Corporation's contact information is listed on the following page.

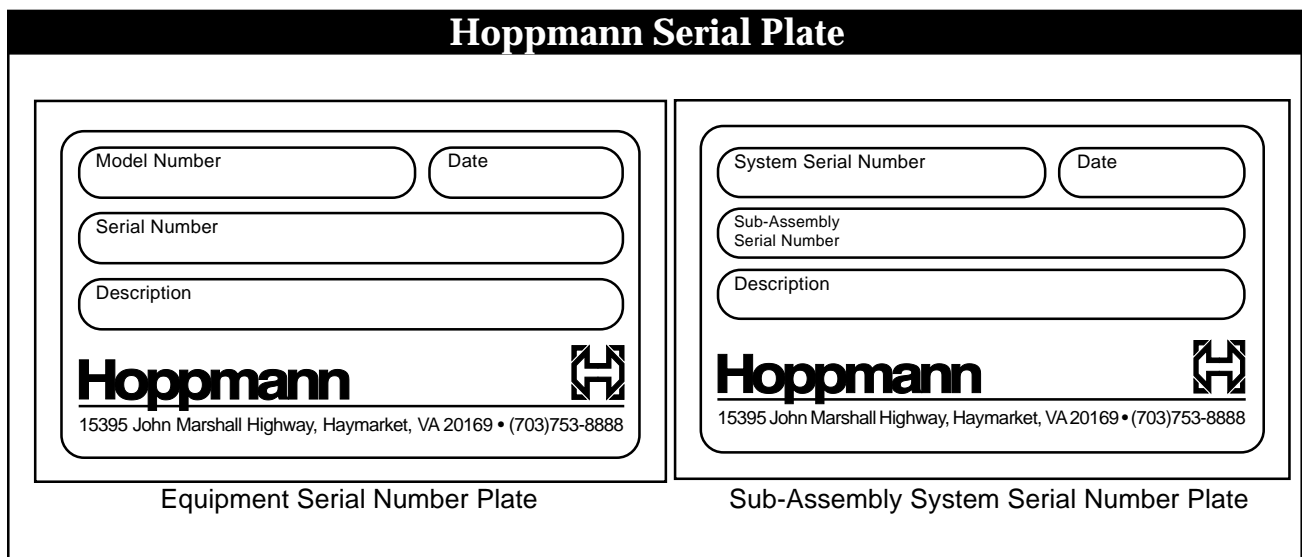

Figure 6-1. Serial Plate Layouts - Equipment and System



Notice to Dealer & OEM Customers:

Some components listed might have been changed by your dealer or OEM to work better with your application. To avoid ordering the wrong replacement part, verify the part number listed in the insert to the back of this manual when you place your order with your dealer or OEM.

In North America:

Hoppmann Corporation
15395 John Marshall Highway
Haymarket, VA 20169
Phone: (703) 753-8888 Toll Free: (800) 368-3582
Fax: (703) 753-7485
e-mail: spares@hoppmann.com
website: www.hoppmann.com

In Europe:

Hoppmann International GmbH
Max-Planck-Str. 95
27283 Verden
Germany
Telefon: 04231 / 96450
Telefax: 04231 / 65000
e-mail: info@hoppmann-int.de
website: www.hoppmann-int.de

Warranty

Hoppmann Corporation warrants that each item of its own manufacture delivered hereunder shall, at the time of delivery and for a period of twelve (12) months thereafter, be free from defects in materials or workmanship; and if any such item shall prove to be defective in material or workmanship under normal intended usage and maintenance during the warranty period, upon examination by Hoppmann Corporation, then Hoppmann Corporation shall repair or replace, at its sole option, such defective item at its own expense; provided, however, that the owner shall be required to ship such defective item, freight prepaid, to Hoppmann Corporation's plant from where it was shipped. The warranty on components not manufactured by Hoppmann Corporation, but a part of the **feeder**, is limited to the warranty provided by the original manufacturer of said components to the extent, and only to the extent, that such original manufacturer actually honors such warranty. **All warranties hereunder are expressly limited to the repair or replacement of defective items as set forth herein, and in no event shall Hoppmann Corporation be liable for special, incidental or consequential damages by reason of any breach of warranty or defect in material or workmanship. Hoppmann Corporation shall not be responsible for repair or replacement of items which have been subjected to neglect, accident or improper use, or which have been altered by other than authorized Hoppmann Corporation personnel.**

This warranty is in lieu of other warranties, express or implied. All implied warranties, including but not limited to the implied warranties of merchantability and fitness for a particular purpose are hereby excluded.



Notes

Notes



Scheduled Mechanical Maintenance

Regular Maintenance

- ▶ Clean as needed
- ▶ Inspect chain tension at six (6) month intervals
- ▶ Lube idler assembly (single drive)

Performed by (initial) _____ (date) _____

Performed by (initial) _____ (date) _____

Performed by (initial) _____ (date) _____

Performed by (initial) _____ (date) _____

Performed by (initial) _____ (date) _____

Performed by (initial) _____ (date) _____

Performed by (initial) _____ (date) _____

Performed by (initial) _____ (date) _____

Performed by (initial) _____ (date) _____

Performed by (initial) _____ (date) _____

Performed by (initial) _____ (date) _____

Performed by (initial) _____ (date) _____

Scheduled Electrical Maintenance

Once Every 6 Months

- ▶ Inspect/replace motor brushes

Performed by (initial) _____ (date) _____

Performed by (initial) _____ (date) _____

Performed by (initial) _____ (date) _____

Performed by (initial) _____ (date) _____

Performed by (initial) _____ (date) _____

Performed by (initial) _____ (date) _____

Performed by (initial) _____ (date) _____

Performed by (initial) _____ (date) _____

Performed by (initial) _____ (date) _____

Performed by (initial) _____ (date) _____

Performed by (initial) _____ (date) _____

Maintenance Information - See Chapter 4.