



Model FR-20 & FR-30 Centrifugal Feeders

ANSI/Metric Installation & Maintenance Manual



Refer all servicing to qualified personnel.

This manual is written for qualified mechanics and electricians who must install or service the FR-20 or the FR-30 Centrifugal Feeders.

Do not use this manual with feeders that have serial numbers lower than 19448, except where noted.

Please copy the feeder's serial plate information:

Model Number:

Serial Number/Date:

Inventory Number (Check One):

- | | |
|-------------------------------------|-------------------------------------|
| <input type="checkbox"/> FR20XXXDSA | <input type="checkbox"/> FR30XXXDSA |
| <input type="checkbox"/> FR20XXXASA | <input type="checkbox"/> FR30XXXASA |
| <input type="checkbox"/> FR20XXXASM | <input type="checkbox"/> FR30XXXASM |



Second Edition, Revision 3. All Rights Reserved.
Copyright © 2005,1996, 1994, 1992 by Shibuya Hoppmann
13129 Airpark Drive, Suite 120
Elkwood, Virginia 22718

Phone: (540) 829-2564

Toll Free: (800) 368-3582

Fax: (540) 829-1724

www.hoppmann.com • email: publications@hoppmann.com

Quick Start

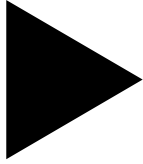

About this Manual

Assumptions This manual is written for a qualified mechanic or electrician who must install or service the FR-20 or FR-30 feeder. All procedures in this manual should be performed by you or under your direction.

Models Covered This manual covers eight models. If you are unsure which model you have, locate the inventory number on the serial plate of the feeder.

<u>Inventory No.</u>	<u>FR-20 ANSI</u>	<u>Inventory No.</u>	<u>FR-30 ANSI</u>
FR20XXXDSA	<i>Stainless Steel</i>	FR30XXXDSA	<i>Stainless Steel</i>
FR20XXXASA	<i>Stainless Steel</i>	FR30XXXASA	<i>Stainless Steel</i>

<u>Inventory No.</u>	<u>FR-20 Metric</u>	<u>Inventory No.</u>	<u>FR-30 Metric</u>
FR20XXXASM	<i>Stainless Steel</i>	FR30XXXASM	<i>Stainless Steel</i>

Caution Symbols and Messages



Caution symbols and messages in this manual call attention to hazardous voltages, moving parts and other hazardous conditions.

The exclamation point caution symbol denotes possible personal injury and/or damage to the equipment.

The lightning bolt caution symbol denotes possible personal injury and/or damage to the equipment from electrical hazards.

Acknowledgments

Grateful acknowledgment is made to HCCI for permission to reproduce the chain tensioning graphic in Chapter 5. Plug-In Horsepower Resistor® is a registered trademark of KB Electronics Inc. for its electronic motor control circuit apparatus.

Equipment Improvements & Document Revisions Notice

Hoppmann Corporation continually improves its products, and reserves the right to change or discontinue specifications and designs shown in this manual without notice and without incurring obligation. Hoppmann Corporation has made every effort to verify the information contained in this manual, but reserves the right to correct any error at the time of the manual's next revision. This manual is subject to change without notice.

04/2006

Before You Start

As-Built Documentation This manual does not contain as-built documentation. Obtain as-built documentation from your direct supplier. If you purchased your tooled feeder directly from Hoppmann Corporation, you will automatically receive as-built tooling and changeover documentation in your System Operations Manual.

Tools You Will Need The model FR-20 and FR-30 feeders are offered in both ANSI and metric versions. For maximum compatibility, ANSI units are classified as “soft ANSI” construction, meaning that metric threads and hardware are used throughout. Both metric and ANSI units require metric tools for repair and/or adjustment. If your direct supplier tooled your metric feeder with ANSI hardware, you will need ANSI tools as well.



Any part of the feeder that touches your parts has been precision tooled to match your parts. Do not move tooling or change feeder settings except as directed in this manual, your System Operations Manual or by your direct supplier. You may void your warranty and negatively affect the performance of your feeder.

Table of Contents

	Page		Chapter
Quick Start	2	About this Manual	
	3	Before You Start	
Feeder Description & Specifications	7	Overview of the FR-20 & FR-30	1
		<i>Figures:</i>	
	6	Figure 1-1. FR-20 & FR-30 Feeder Exploded View	
	8	Figure 1-2. FR-20 Feeder Specifications	
	9	Figure 1-3. FR-30 Feeder Specifications	
Safety Precautions	11	Safety Precautions	2
	11	Operating & Maintenance: Do's & Don'ts	
Installation & Startup	13	Unpacking & Inspection	3
	13	Physical Setup	
	14	Starting The Feeder For The First Time	
	15	How to Set Proper Bowl Speed	
	16	Running Product For The First Time	
	16	General Tips	
		<i>Figures:</i>	
	15	Figure 3-1. Measuring & Changing Bowl Speed	
	17	Figure 3-2. DC ANSI Wiring Diagram	
	18	Figure 3-3. DC Metric Wiring Diagram	
Preventive Maintenance	19	General Cleaning	4
	19	Lubrication	
	20	Gearmotor Lubrication (ANSI Models Only)	
	20	Brush Inspection (ANSI Models Only)	

	Page	Chapter	
Repair & Troubleshooting	21	Adjusting Bowl Runout	5
	22	Torque Limiter: Replacement/ Adjustment	
	24	Adjusting Chain Tension	
	24	Adjusting Backup Ring Clearance	
	28	Removing Bowl for Machining	
	28	Replacing Major Bearings	
	29	If Parts Jam: General Tips	
		<i>Figures:</i>	
	22	Figure 5-1. Torque Limiter Assembly	
	24	Figure 5-2. Chain Tension	
	25	Figure 5-3. Old vs. New Serial Number	
	26	Figure 5-4. Older Style Backup Ring	
	27	Figure 5-5. Current Style Backup Ring	
	28	Figure 5-6. Machinable Bowl Surfaces	
31	Figure 5-7. FR-20 & FR-30 Feeder Troubleshooting		
32	Figure 5-8. FR-20 & FR-30 Feeder Troubleshooting, Cont.		
Spare Parts	33	Notice to Hoppmann Customers	6
	33	Notice to Dealer & OEM Customers	
	33	In North America	
	33	In Europe	
	34	ANSI FR-20 Replaceable Spares	
	35	Metric FR-20 Replaceable Spares	
	36	ANSI FR-30 Replaceable Spares	
	37	Metric FR-30 Replaceable Spares	
	38	Warranty	
	40	Scheduled Electrical Maintenance	
40	Scheduled Mechanical Maintenance		

★ Replaceable Spare:
See Pages 34-37.

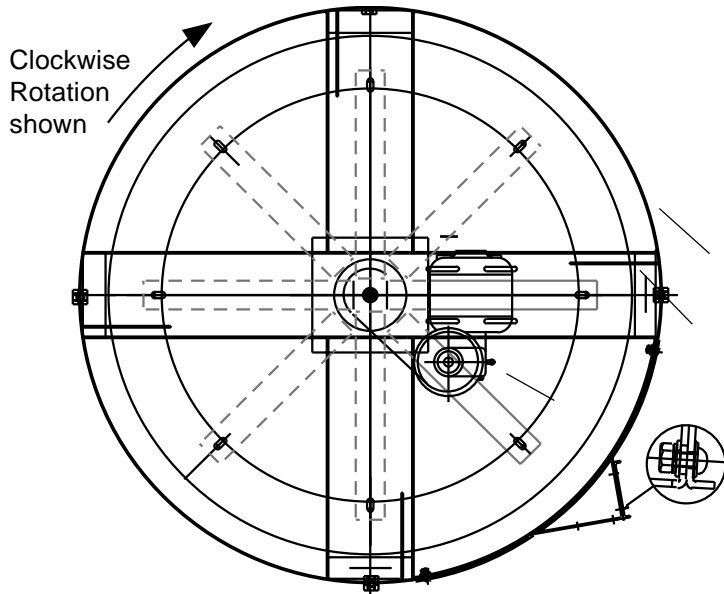

FR-30 Top View

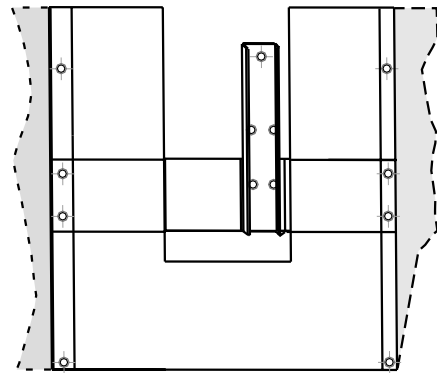

Frame Side Cover

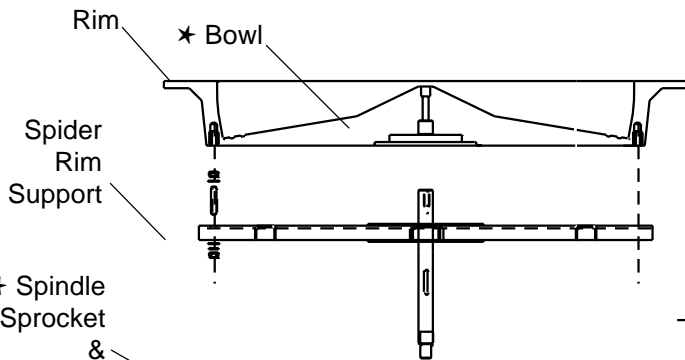

FR-30 Side View

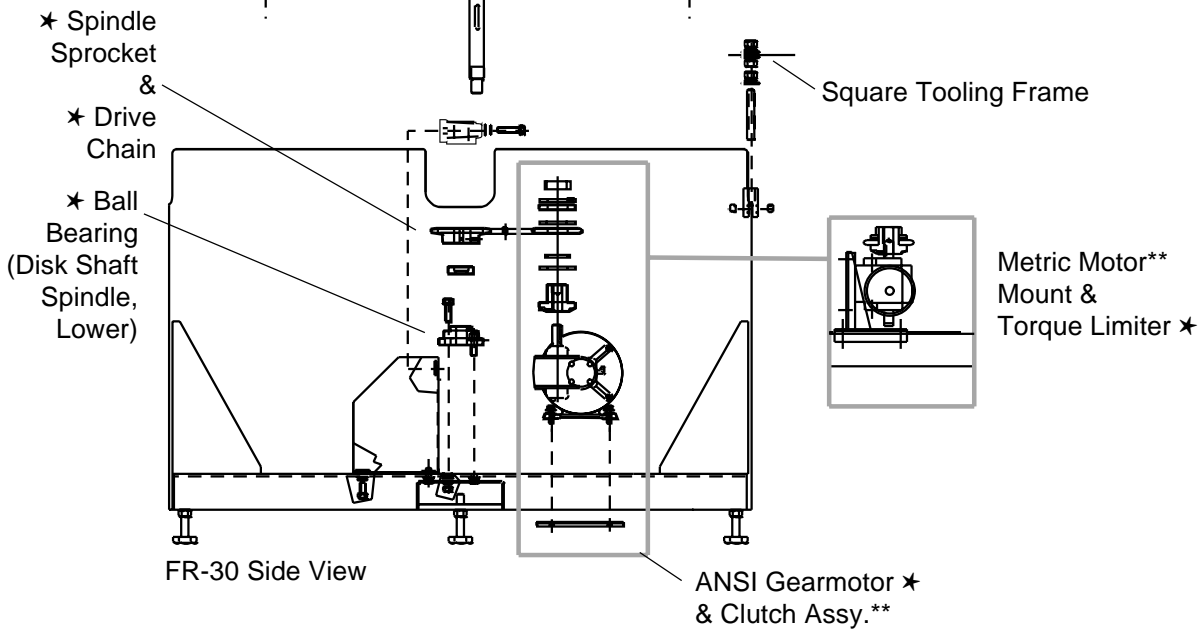

**Motor/Clutch Assembly may be different. Drawing is for location only.

★ Replaceable Spare.
See Pages 37-40.

Figure 1-1. FR-20 & FR-30 Feeder Exploded View

Feeder Description & Specifications

1

Overview of the FR-20 & FR-30

FR-20 vs. FR-30 The FR-20 & FR-30 Centrifugal Feeders unscramble, feed and orient product. Simply put, it delivers aligned product. Except for obtainable rates and the size of product, the FR-20 and FR-30 function identically. Generally, the FR-30 is used to handle larger product or achieve higher output rates.

Operation **Step 1 The Feeder Accepts Your Product.** Every FR-20 and FR-30 operates in the same basic way. The feeder accepts product from a separate bulk supply hopper or prefeeder. Product drops randomly into the bowl, a few at a time. (Shibuya Hoppmann centrifugal feeders function best when product is carefully metered from bulk by a prefeeder.)

Step 2 The Feeder Loads and Qualifies Your Product. After dropping into the bowl, product in the desired orientation is pushed up the stationary ramp. This process may be assisted in some applications by compressed air. After the product has been pushed up the ramp, it is loaded onto the moving rim of the bowl. The rim moves the product past mechanical, pneumatic and/or optical qualifiers which reject product that are not in the desired orientation. Improperly oriented product are recirculated.

Step 3 The Feeder Delivers Your Product. Finally, product moves off the bowl's rim and out of the feeder in the proper orientation, in a rapidly moving and in a randomly spaced stream. Shibuya Hoppmann centrifugal feeders deliver product almost immediately, so parts simply don't have time to get scuffed up.

Rate Shibuya Hoppmann feeders typically handle product at rates between 20 and 2000 parts per minute. Your particular product's characteristics and your desired production speed will affect the output rate.

FR-20 Feeder Specifications

Product Specifications:

	<u>ANSI</u>	<u>Metric</u>
A. Outer Wall Diameter	27.25"	693mm
B. Overall Height	24.25" ± 1"	615mm ±25mm
C. Discharge Height	17.5"	445mm
D. Bowl Outside Diameter	24.81"	631mm
E. Rim Width	2.32"	59mm
Total Indication Runout, ID*	0.03"	0.76mm

Standard Models:

	<u>FR20XXXDSA</u>	<u>FR20XXXASA</u>
Part Number	<u>FR20XXXDSA</u>	<u>FR20XXXASA</u>
Motor Style	DC	AC
Motor Voltage	90V	180V
Horsepower	1/8 hp	93 W
Total Equipment Weight	210 lbs.	95 kg

Required Accessories:

	<u>Clockwise</u>	<u>Counter-Clockwise</u>
Direction/Rotation	<u>ARCWFR20SU</u>	<u>ARCCFR20SU</u>
Air Ramp	<u>BUCWFR20SU</u>	<u>BUCCFR20SU</u>
Square Frame Backup Ring		

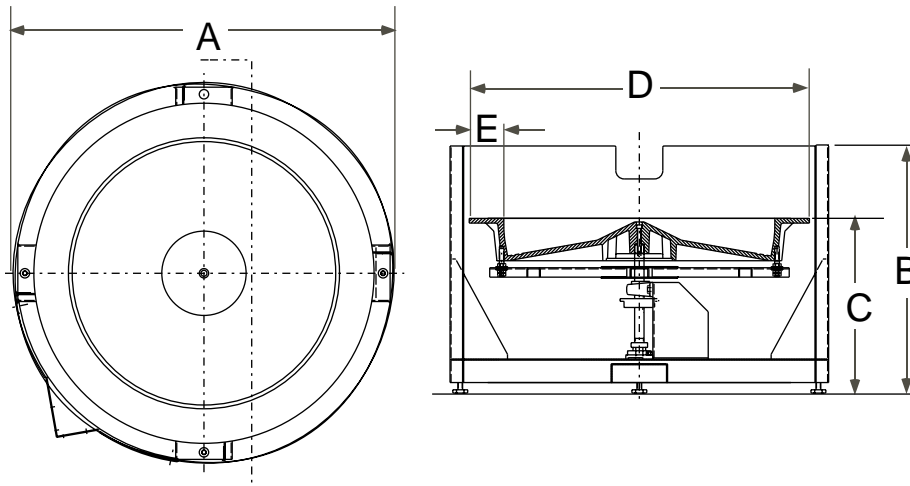

Your direct supplier may have changed some of these specifications during tooling to better match your application's requirements.

* Standard Bowl Total Indication Runout - Inside Diameter

Figure 1-2. FR-20 Feeder Specifications

FR-30 Feeder Specifications

Product Specifications:

	<u>ANSI</u>	<u>Metric</u>
A. Outer Wall Diameter	40.50"	1029mm
B. Overall Height	26.25" ± 1"	667mm ±25mm
C. Discharge Height	18.5"	470mm
D. Bowl Outside Diameter	36.13"	918mm
E. Rim Width	3.63"	92mm
Total Indication Runout, ID*	0.03"	0.76mm

Standard Models:

	<u>FR30XXXDSA</u>	<u>FR30XXXASA</u>
Part Number	<u>FR30XXXDSA</u>	<u>FR30XXXASA</u>
Motor Style	DC	AC
Motor Voltage	90V	240V
Horsepower	1/8 hp	93 W
Total Equipment Weight	350 lbs.	159 kg

Required Accessories:

	<u>Clockwise</u>	<u>Counter-Clockwise</u>
Direction/Rotation	<u>ARCWFR30SU</u>	<u>ARCCFR30SU</u>
Air Ramp	<u>BUCWFR30SU</u>	<u>BUCCFR30SU</u>
Square Frame Backup Ring		

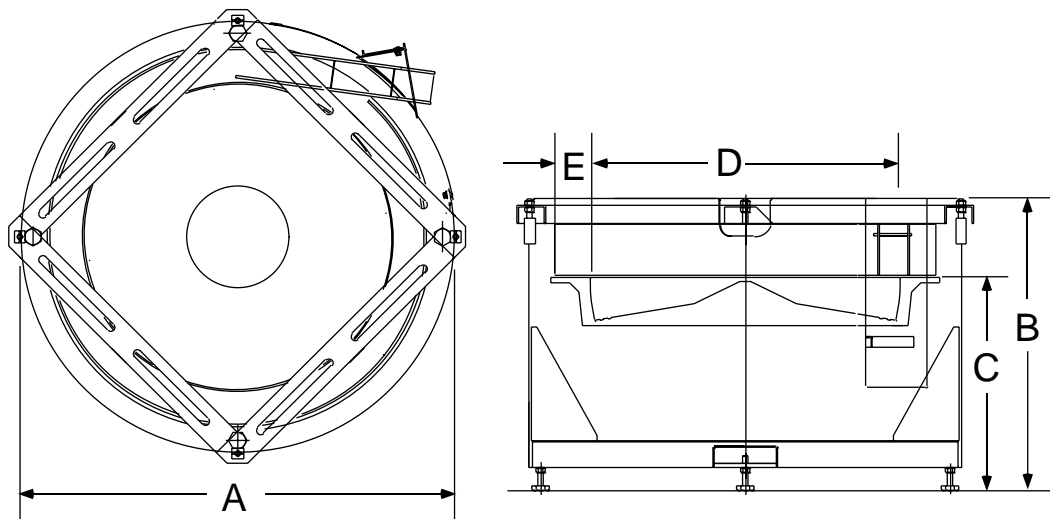

Your direct supplier may have changed some of these specifications during tooling to better match your application's requirements.

* Standard Bowl Total Indication Runout - Inside Diameter

Figure 1-2. FR-30 Feeder Specifications

Notes

Safety Precautions

2

Warnings & Cautions



Turn Off Power! Before servicing, make sure you have turned off compressed air and electrical power in a way which prevents accidental reactivation. Padlock and clearly tag the appropriate electrical and pneumatic disconnects. Lockout/tagout procedures are covered in United States Code of Federal Regulation (CFR) Title 29 Part 1910.147, "The Control of Hazardous Energy."



Dress Appropriately! Reduce the risk of injury from moving parts by securing loose sleeves and other clothing. Don't wear loose jewelry or neckties near the feeder. Wear safety glasses or other protective eyewear when servicing the feeder. Never place hands or tools in the feeder when it is operating.



Install Safety Covers! Make sure the feeder remains safe to operate. Be sure all safety covers have all been installed before returning the feeder to normal operation. Safety covers on the FR-20 and FR-30 feeders include any covers installed by your direct supplier, as well as the exit area cover (which protects the operator from moving sprockets and belts.)

Operating & Maintenance: Do's & Don'ts

Don't Give the Feeder Too Much Product. Don't overload the feeder, or it may jam or lose rate. Product must be carefully metered into the feeder from bulk. Allow only enough product into the feeder to keep the line running at the required rate.

Don't Run the Feeder Too Fast. Don't run the bowl faster than the linear feet per minute recommended by your direct supplier. If you do, the orientation qualifiers cannot function as efficiently, and the feeder may jam or lose rate.

Don't Adjust Air Jet Flow Controls. It's okay to adjust the main air regulator to its correct setting for your installation. However, air jets and their *individual flow controls* have all been carefully preset to work with your product; they should *never* need adjustment. If you move air jets or adjust their individual flow controls, the feeder may jam or lose rate.

Do Perform Preventive Maintenance. To keep the feeder running without unexpected repairs and resulting "down" time, regularly perform the preventive maintenance procedures in Chapter 4.



Do Carefully Replace Any Tooling You Remove. To gain access for repairs, you may need to remove tooling. Because Shibuya Hoppmann and your dealer or OEM have no control over such activities, they can not be responsible for any tooling you remove. ***Carefully document the position of any tooling before you begin.*** If you fail to replace all tooling exactly as it was, you may create difficult and time consuming problems for yourself.

Don't Install the Feeder Near Flammable Gas, Vapor or Dust. Do not install a feeder in these conditions unless you install additional, approved explosion-proof or dust ignition-proof enclosures. Without such additional enclosures, normal sparking of the brushes inside the motor could ignite flammable gas, vapor or dust.

Installation & Startup

3

Unpacking & Inspection



Step 1 **Inspect & Unpack the Crate.** Remove packing materials from sensors, tooling and moving parts. Make a visual check to be sure parts have not come loose during shipping. If you find any concealed damage, call the shipping carrier and your direct supplier immediately. ***Don't attempt to fix the problem yourself unless told to do so by your direct supplier.***

Step 2 **Record Serial Numbers.** If you have not already done so record, on the front of this manual, the feeder's model and serial number.

Physical Setup

Step 1 **Position the Feeder.** Place the feeder as shown on the equipment layout drawing provided by your direct supplier.

Step 2 **Level the Feeder.** Using a carpenter's level, adjust the leveling feet. Tighten the locknuts on the leveling feet. (In some applications, leveling feet are not used because the feeder is connected directly to other framework.)

Step 3 **Connect Your Output Device.** Check that product can move smoothly from the exit of the feeder to your output device (deadplate, conveyor, gravity track or powered rollers, i.e.). Ensure that product won't jam or lose their orientation as they move to the output device.

Step 4 **Position the Prefeeder.** Now, place your bulk supply hopper or prefeeder into position. Follow the equipment layout drawing provided by your direct supplier, or the feeder may not operate correctly. *If you are providing your own prefeeder, continue reading. Otherwise, skip to Step 5.*

If you are supplying your own prefeeder, you are responsible for:

- ▶ Providing and installing the feeder's bowl level switch so it can control the product flow of your prefeeder.
- ▶ Setting the timing delay for the feeder's bowl level switch.
- ▶ Correctly positioning the prefeeder. Generally, the prefeeder must discharge product to fall on the lowest side of the feeder's disc, halfway between its center and its outside diameter. Take a handful of product and drop them from the snout of your prefeeder into the feeder bowl. Avoid product bouncing up off the disc onto the rim of the feeder bowl, this could disturb properly oriented product. Reposition the prefeeder (as often as necessary) until product lands correctly.

Step 5 **Connect Power and Air.** Connect your feeder to main power and compressed air (if applicable). Don't change the feeder's main air regulator; it should already be correct when you receive the feeder.

Starting the Feeder for the First Time

Step 1 **Secure Safety Covers and Clothes.** Before turning on power and air, make sure safety covers are in place and that you are dressed appropriately for safety.

Step 2 **Turn on Power and Air.** Turn on the feeder's power. If applicable, turn on the feeder's main air regulator.

Step 3 **Check for Rubbing Parts.** Run the prefeeder, feeder and output device without product. In the unlikely event that you hear squeaks and squeals (there should be none), shut down immediately and check for any remaining packing, such as between the backup ring and the rim of the bowl.

How to Set Proper Bowl Speed

Ask your direct supplier for the actual linear feet per minute at which the bowl should rotate. For reliability, set the bowl to match that speed.

- ▶ To set bowl speed, you will need a hand-held tachometer (analog or digital) with a surface speed wheel indicator (see Figure 5-1).
- ▶ This procedure is performed with the power on and the feeder operating. If your direct supplier has installed a cover over the bowl, you will need to open it before proceeding.

Step 1 Turn on Feeder. Turn on the feeder and run it without product.

Step 2 Set Bowl Speed. To set the bowl speed, place the hand-held tachometer (with surface speed indicator attachment) on the inner wall of the moving bowl, at its most upper inside diameter. Adjust the bowl speed until the bowl is moving at correct number of linear feet per minute (FPM).

Step 3 Record New Settings. Turn off the feeder. Mark dial plate with new setting and remove any old marks.

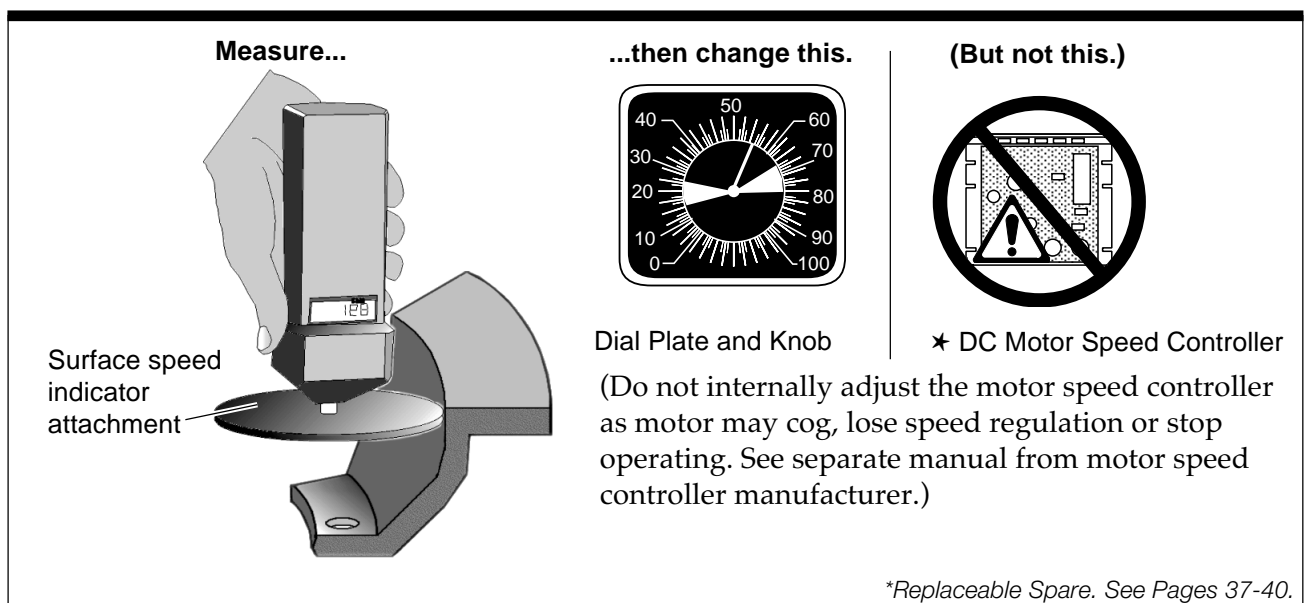

Figure 3-1. Measuring & Changing Bowl Speed

Running Product For The First Time

Step 1 Verify Changeover Setup. If your feeder is tooled to run multiple product, ensure the feeder is set up for the product you want to run.

Step 2 Inspect Product at Exit. Inspect the exit of the feeder. If product is exiting the feeder properly oriented, at the required rate and without jamming, then installation is complete. Otherwise, continue with Step 3. ***At this point, do not adjust the flow controls on any air jet.***



Step 3 Verify Prefeeder Speed. Normally this step is completed by your direct supplier; however, if you are providing your own prefeeder, you'll have to set the prefeeder's speed. To do this, turn the prefeeder's speed control all the way down, then turn on the feeder.

▶ Slowly, raise the prefeeder's speed control (you may need to take several minutes) until enough product exits the feeder to keep the line running at the required rate.



Stop raising the prefeeder speed when enough product is exiting the feeder. If you don't stop raising the prefeeder speed, you will overload the feeder and reduce its output.

General Tips

▶ After your feeder is set up and running, observe the flow of product at each transition point. Later, if a problem occurs, observe these transition points to help pinpoint the cause.

▶ Listen to the way the feeder sounds when it is running properly. If it suddenly sounds different, investigate why.

FR-20/30 DC ANSI-Suggested Wiring Diagram

* Replaceable Spare:
See Pages 37-40.

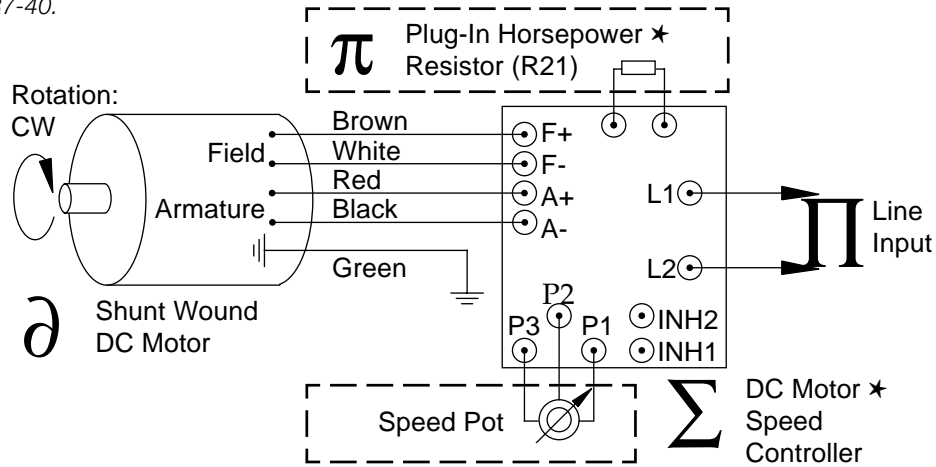

Notes:

- ▶ **Do not use** this diagram if your feeder or motor speed controller are different than shown.
- ▶ **Start-stop options:**
 - Option 1:* Open P3 circuit of speed pot with a pilot duty switch circuit for stop.
 - Option 2:* Interrupt line voltage.
- ▶ **For additional information:** See “KBIC® Solid State DC Motor Speed Control Installation and Operating Instructions” in U.S.A. from KB Electronics, Inc., Brooklyn, NY 11207; in U.K. from: EUREP, Lichfield Staffs; in Germany from: Moll Motor Motors, Donaustrasse, Austria or Suter Form-O-Tronic AG, Zurich, Switzerland.

Specifications

∂	Motor	1/5 hp Motor, 90VDC SBY_Hoppmann Part Number: MOTRP.20HP
Σ	DC Motor Speed Controller	90VDC, ANSI, Motor Controller SBY_Hoppmann Part Number: CNTRKBIC01
Π	Line Input	115 VAC
π	Plug-In Horsepower Resistor (R21)	0.10 Ohm SBY_Hoppmann Part Number: RESIKB.100

Figure 3-2. DC ANSI Wiring Diagram

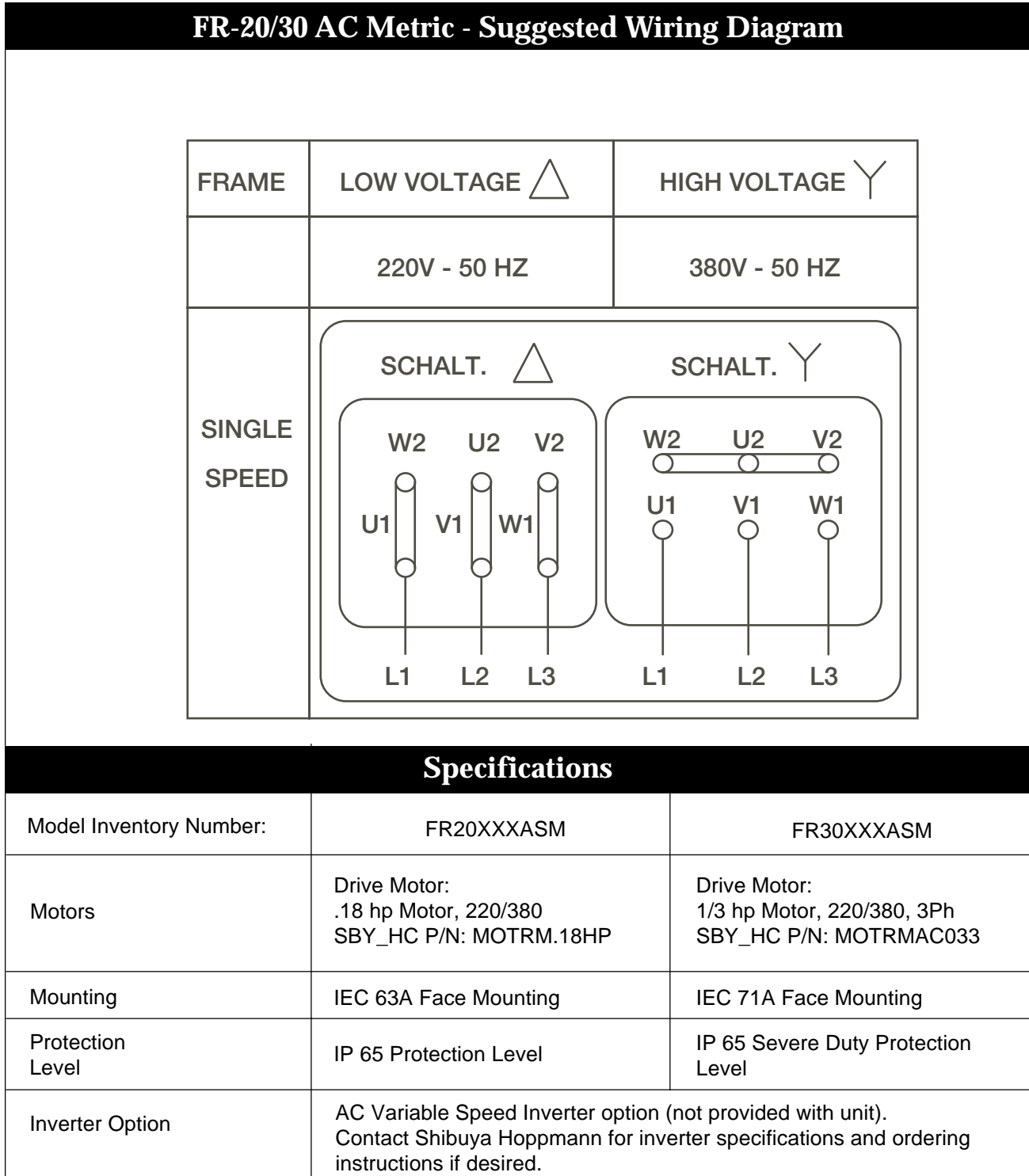

Figure 3-3. AC Metric Wiring Diagram

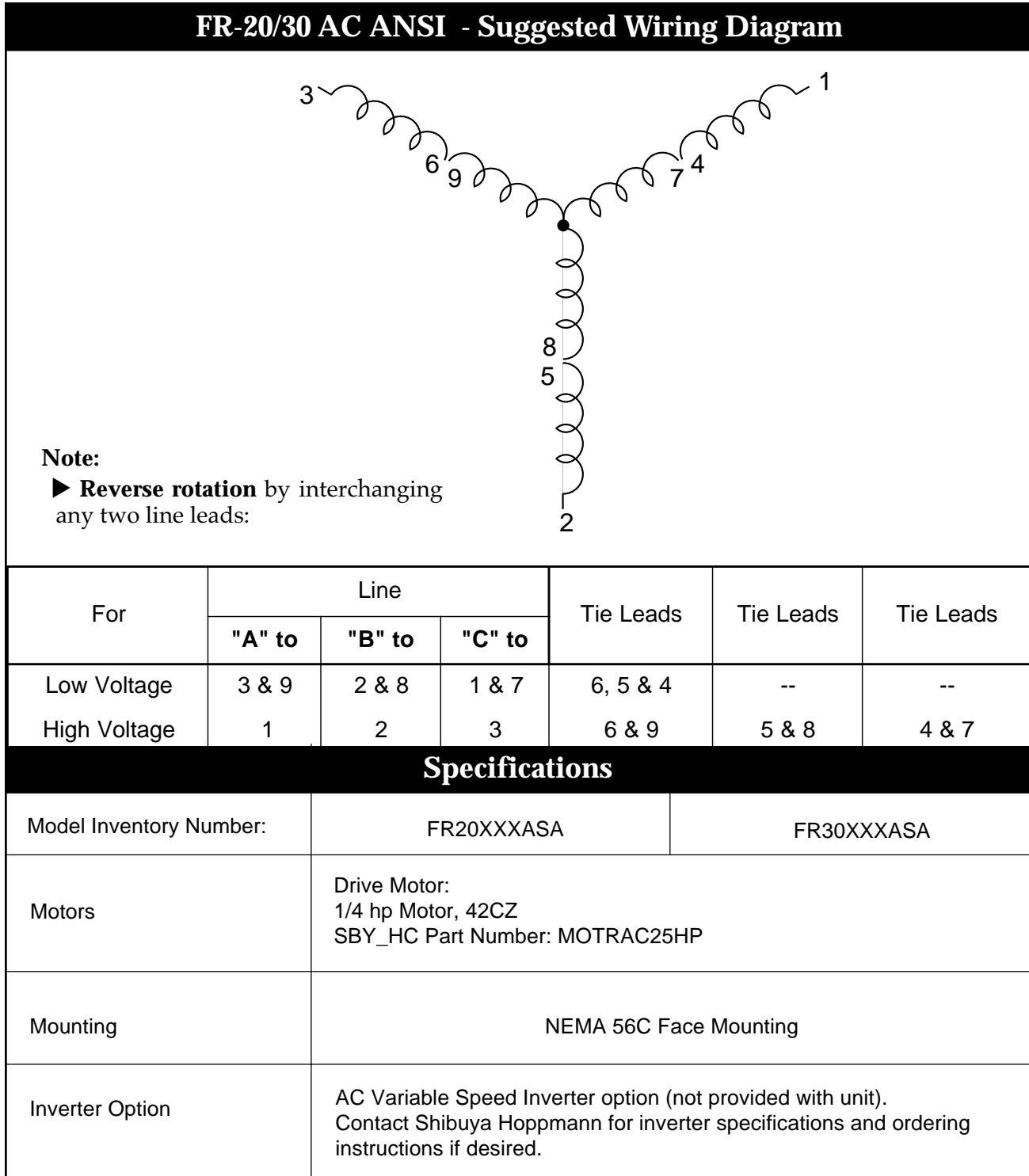

Figure 3-4. AC ANSI Wiring Diagram

Notes

Preventive Maintenance

4

General Cleaning

Outer Frame & Tooling

The Hoppmann Model FR-20 & FR-30 Centrifugal Feeders are not intended for washdown use. If you need to clean the outer frame, safety covers or tooling, use a mild household cleaner.

Bowl & Rigid Disc: "Dusty" Applications

The bowl and rigid disc are self-cleaning when handling most product; however, if your product generates dust or particulate when handled, clean the feeder as often as necessary. For such product, remove dust from the top surface of the rim of the bowl and the rigid disc with a portable vacuum cleaner or dry compressed air.

Lubrication

Bearings

On all FR-20 and FR-30 models, grease nipples for lubrication are located on the outside of the upper and lower spindle bearings. Use any lithium grease conforming to NLGI Grade 2 consistency; the grease should be free of dust, particles and abrasives.

Instead, use the maximum grease capacity of the bearings as a guide; the upper spindle bearing can hold up to about $\frac{3}{8}$ ounces of grease; the lower spindle bearing can hold up to about $\frac{1}{8}$ ounces of grease. Lubricate every 6 to 12 months or 1000 operating hours, whichever comes first.



Because of the danger from moving parts, do not lubricate while the feeder is operating.

Chain & Sprockets

After greasing the bearings, grease the drive chain, spindle sprocket and torque limiter sprocket every six months or 1000 operating hours, whichever comes first. Use standard Moly grease, Lubriplate #3000 (NLGI Grade 2) or equivalent.

Notes

Repair & Troubleshooting

5

Adjusting Bowl Runout

Bowl runout needs to be set if the bowl is removed. Adjust runout with power off and drive chain disengaged. For runout specifications, see Chapter 1.

Step 1 *Main Access.* Disconnect power and air. Remove the cover from the exit area of the feeder.

Step 2 *Remove Drive Chain.* Remove the master link. Disconnect the drive chain from the spindle shaft sprocket.

Step 3 *Adjust Vertical Runout.* Attach a dial indicator to the inside of the feeder frame. Set the indicator contact point vertical, resting on the top of the rim of the bowl, up to $1/4$ " (6 mm) from the bowl's upper inside diameter (ID). Loosen the jam nuts and locknuts (above and below) each arm of the bowl spider, one arm at a time. Repeat as necessary while checking runout. Don't tighten the jam nuts until Step 4.



Do not adjust spider rim support arms without monitoring runout, because if you misalign any one spider rim support arm, you may damage the feeder bowl.

Step 4 *Adjust Horizontal Runout.* Move the indicator contact point horizontal, resting on the inner wall of the bowl, up to $1/4$ " (6 mm) from the bowl's upper ID. Gently tap the bowl's ID with the palm of your hand or a rubber mallet. Inspect vertical runout and adjust again if necessary. Continue alternating between horizontal and vertical runout until both are within specification. Tighten locknuts and jam nuts by hand firmly but not forcibly.

Step 5 *Check Exit.* Ensure that the proper relationship still exists at each transition between the rim of bowl and output device (deadplate, conveyor, gravity track or powered rollers, i.e.).

Step 6 *Check Backup Ring Clearance.* Ensure that the proper as-tooled gap still exists between the bottom of the backup ring and the rim of the bowl.

(Feeders for most product are tooled with approximately 1/8" gap, but for some small product the gap is less; consult your as-built documentation.) Adjust tooling ring up or down if necessary.

Step 7 **Replace Chain & Cover.** Install drive chain. Inspect chain tension. Replace cover and connect power and air. Feeder is ready for use.

Torque Limiter: Replacement/Adjustment

The torque limiter allows the motor to slip harmlessly in the event of a parts jam. Severe humidity or dryness, lubricants or surface corrosion on bushings or the torque limiter's drive sprocket may reduce the effectiveness of the torque limiter. The torque limiter should be inspected and adjusted if the rim is free wheeling.

FR-20 Parts Depending on its serial number, your FR-20 contains either a motor sprocket or one of two types of torque limiters. For best results, use identical replacement parts. Replacement parts by serial number are listed for the metric FR-20 in Chapter 6, Spare Parts. **Retrofitting a torque limiter onto a unit that has none is not required.**

Replacement **Step 1** **Disconnect Power.** Disconnect power and air in such a way to prevent accidental reactivation.

Step 2 **Gain Access.** Remove exit cover and drive chain for the rim.

Step 3 **Remove Torque Limiter.** Remove and disassemble torque limiter. Inspect and replace any broken or worn parts. Observe order of components (see Figure 5-1).

Step 4 **Assemble Torque Limiter.** Assemble the torque limiter. Tighten adjusting nut by hand. Do not completely flatten the disk spring.

Step 5 **Replace Chain Tension.** Replace the chain and inspect chain tension (see page 22, *Adjusting Chain Tension*).

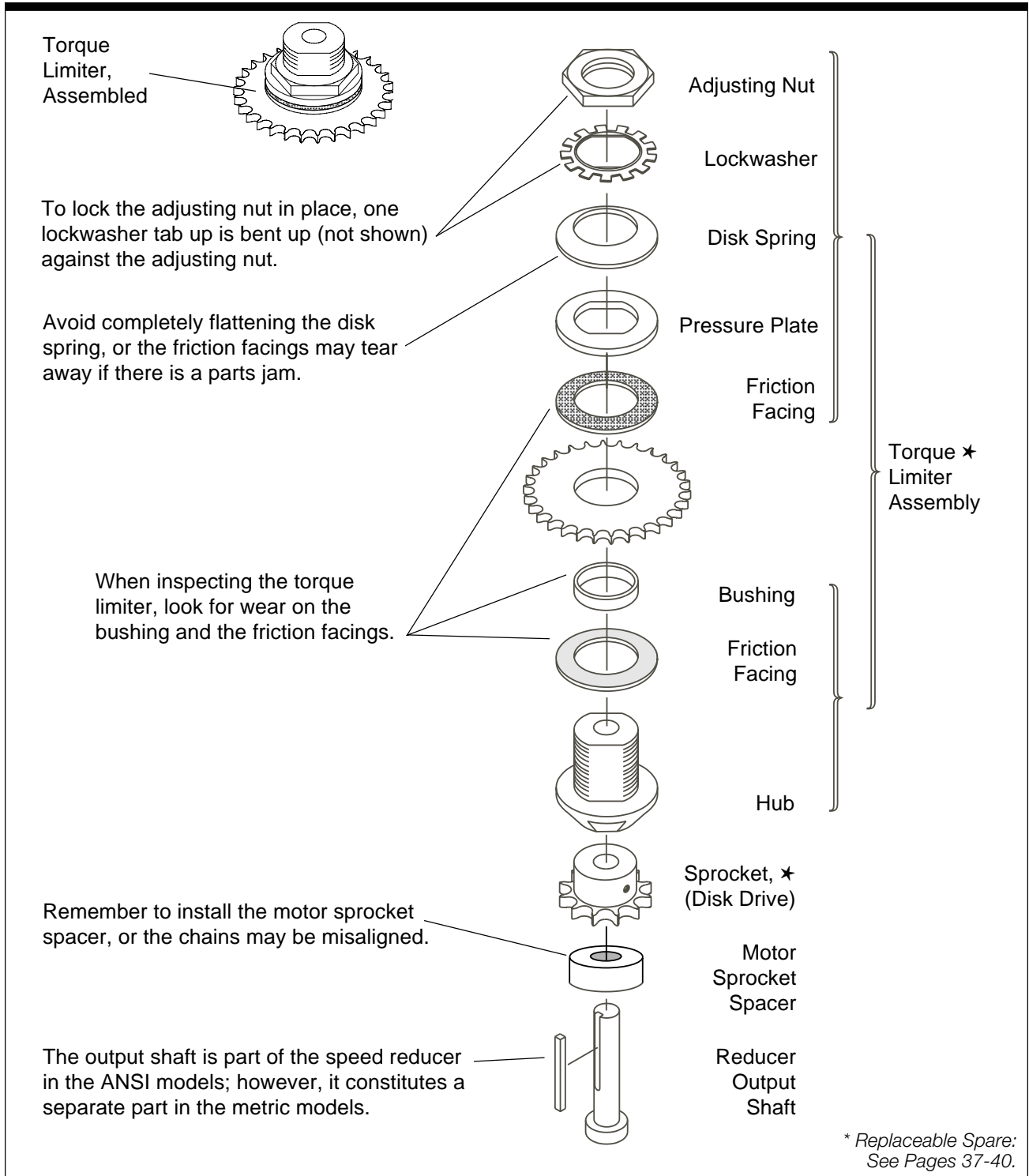

Figure 5-1. Torque Limiter Assembly

Chain Drive Nomenclature - FR-20/30 Feeder

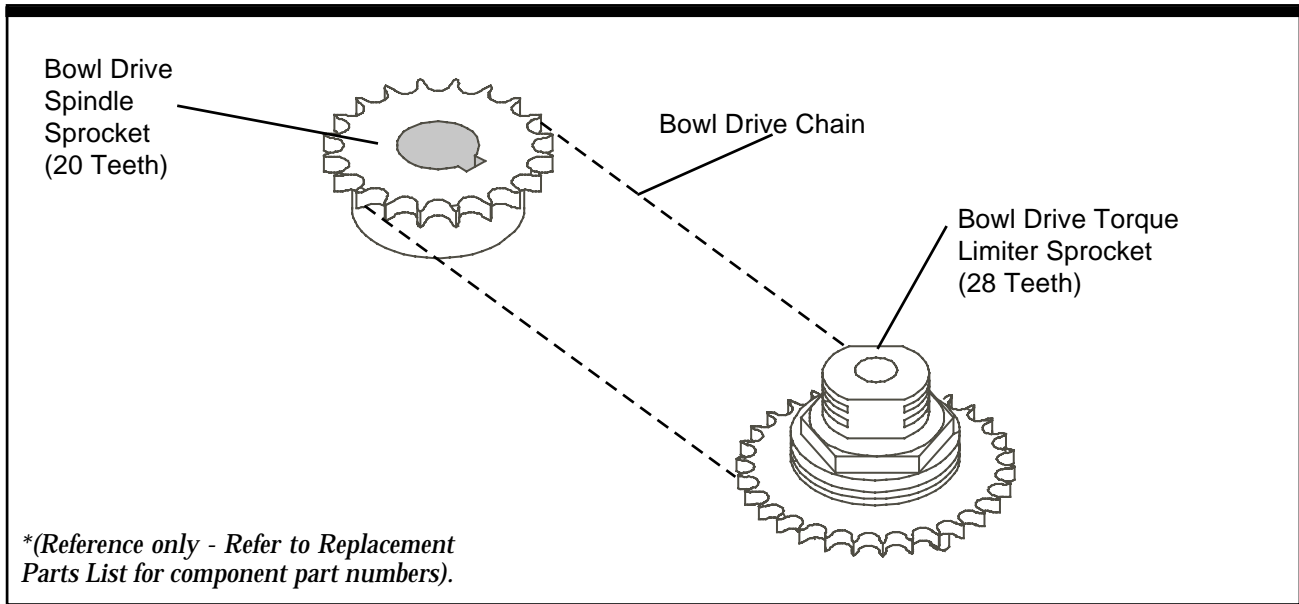

Figure 5-2. FR-20/FR-30 Feeder Drive Sprocket Location Diagram

Inventory No.'s: **FR20XXXDSA ⓂR20XXXASA ⓂR20XXXASM**
 FR30XXXDSA ⓂR30XXXASA ⓂR30XXXASM

Sprocket Name/Location # of Teeth

Bowl Drive Spindle Sprocket 20 Teeth
 Bowl Drive Torque Limiter Sprocket 28 Teeth

Chain Lengths

FR-20 - Bowl Drive Chain (51 Links) #40 x 25.5" Long
 FR-30 - Bowl Drive Chain (57 Links) #40 x 28.5" Long

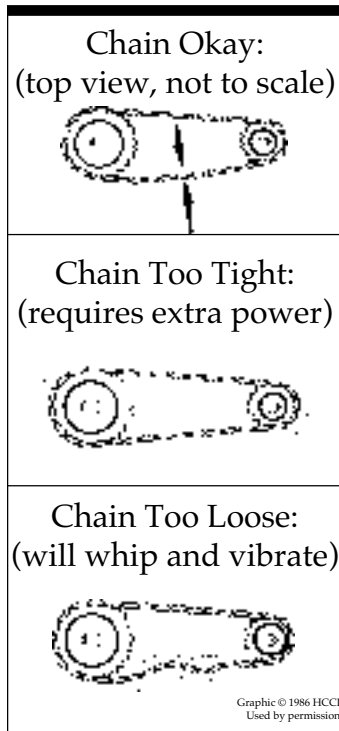

Figure 5-2. Chain Tension

Adjusting Chain Tension

Occasionally the drive chain located under the bowl may need adjustment. The drive chain must be tight enough so that it does not whip, vibrate or jump over the sprocket teeth.

To ensure smooth operation, chain tension should be set to 1/4" (6 mm) slack. Measure this by gently pulling the chain in one direction midway between spindle sprocket and friction clutch sprocket.

Step 1 Turn Off Power. Turn off power and remove feeder cover.

Step 2 Loosen Drive. Loosen the mounting bolts of the drive motor.

Step 3 Adjust Tension. Adjust tension of the drive chain by sliding the motor away from the center of the feeder until the proper tension is achieved.

Step 4 Tighten Drive. Tighten the motor mounting bolts. Replace all safety covers and check your work.

Adjusting Backup Ring Clearance

A number of design improvements were made to all models (cold rolled and stainless steel, ANSI and metric) of the FR-20 and FR-30 that affect the backup ring clearance adjustment of the units listed below.

If FR serial no. is **lower** than shown below, follow OLDER STYLE Backup Ring Clearance Adjustment Procedure below. If FR serial no. is **equal to or higher** than shown below, follow CURRENT STYLE Backup Ring Clearance Adjustment Procedure on the next page.

OLDER STYLE Backup Ring Clearance Adjustment Procedure

If it becomes necessary to adjust the backup ring clearance of an FR-20 or FR-30 feeder that contains an older style tooling frame, you must change the backup ring clearance by **raising or lowering the entire bowl and spindle shaft assembly**. (See Figures 5-3 and 5-4 to determine if this procedure applies to you.)

Step 1 Disconnect Power. Turn off power and ensure it can't be accidentally reactivated.

Step 2 Gain Access. Remove the cover from the exit area of the feeder.

Step 3 Check Bowl Runout. Check that bowl runout is within tolerance. (See *Adjusting Bowl Runout*, page 20.)

Step 4 Loosen Lockscrew. Loosen the lockscrew in the threaded clamp collar at the bottom of the spindle shaft. This is located directly above the lower spindle bearing.

Step 5 Check Backup Ring Clearance. There must be enough clearance between the backup ring and the top surface of the bowl rim for the feeder to operate properly. If you have as-built tooling documentation from the dealer or OEM that tooled the feeder, adjust the clearance to that shown on the as-built tooling documentation. Otherwise, consult an authorized Hoppmann dealer or OEM service technician.

Step 6 Raise or Lower the Bowl. To **raise** the bowl, hold the threaded clamp collar while turning the bowl counterclockwise. To **lower** the bowl, hold the threaded clamp collar while turning the bowl clockwise.

Step 7 Tighten Loose Screws. Tighten clamp collar lockscrew when desired bowl height is attained.

Step 8 Readjust Spindle Sprocket (if necessary). If the bowl is raised more than $\frac{1}{16}$ " (1.5 mm), readjust the spindle sprocket to the same height as the friction clutch sprocket, or the drive chain may jerk or bind.

Step 9 ~~Replace~~ **Replace Safety Covers.** Check your work. Replace all safety covers. Feeder is ready to run.

Figure 5-3.
Older vs. Current
Style by Serial No.

<u>'Older style' serial numbers are lower than:</u>		
<u>Feeder Type:</u>	<u>FR-20</u>	<u>FR-30</u>
ANSI, Cold Rolled Steel	15624	16483
ANSI, Stainless Steel	14282	16218
Metric, Cold Rolled Steel	15624	16398
Metric, Stainless Steel	15624	N/A

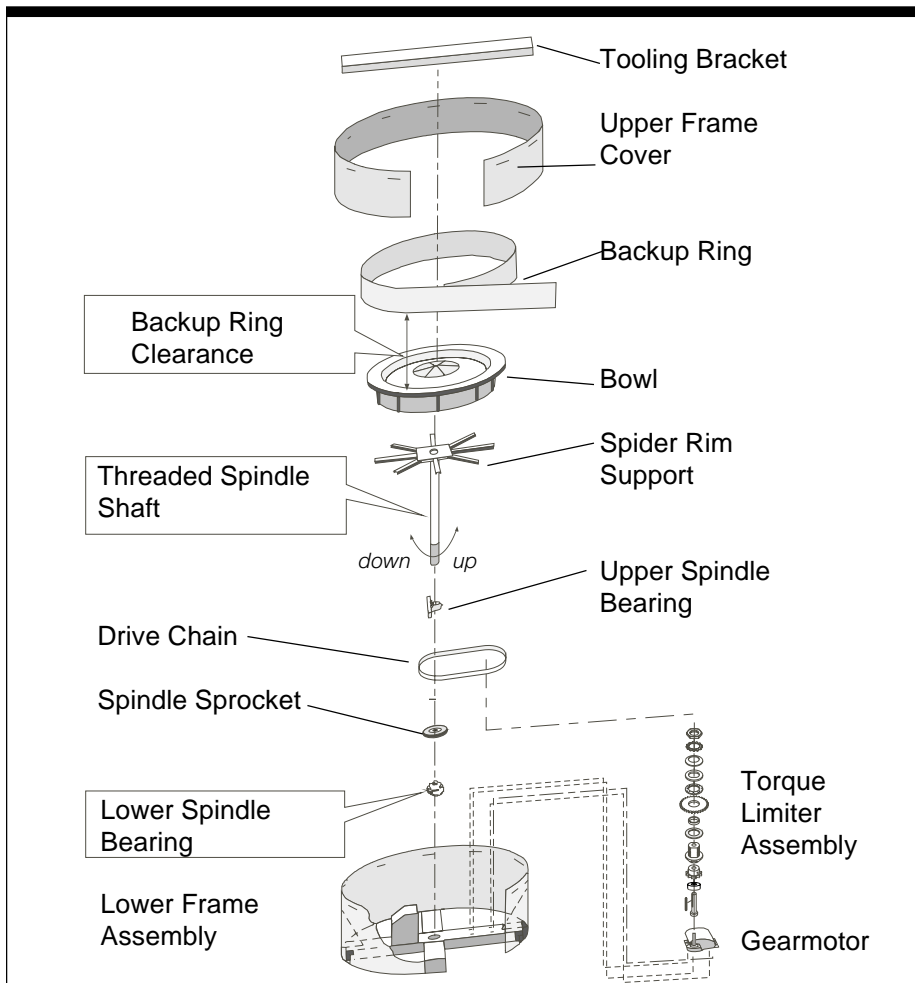

Figure 5-4.
OLDER STYLE
Backup Ring
Clearance Adjustment

To change the clearance between the backup ring and top rim of the bowl on older style FR-20 and FR-30 feeders, loosen the threaded clamp collar on the lower spindle bearing. Next, turn the threaded spindle shaft while holding the lower spindle bearing's threaded clamp collar stationary. To lower bowl, turn clockwise (CW). To raise bowl, turn counterclockwise (CCW).

CURRENT STYLE
Backup Ring Clearance

If it becomes necessary to adjust the backup ring clearance of an FR-20 or FR-30 feeder which contains a current style tooling frame you can change the backup ring clearance by raising the square tooling frame at the four adjustment points around the top of the feeder. This will raise the square tooling frame and everything connected to it, including the backup ring. This is an improvement over the older style tooling frame. Refer to Figure 5-4 and 5-6 to determine if this procedure applies to you.

- ▶ If the square tooling frame adjustment points have been fixed to prevent incorrect adjustments, or
- ▶ If you have an earlier version of the feeder which does not have an adjustable tooling frame, refer to the OLDER STYLE Backup Ring Clearance Adjustment procedure above.



There must be enough clearance between the backup ring and the top surface of the bowl rim for the feeder to operate properly. If you have as-built tooling documentation from the dealer or OEM that tooled the feeder, adjust the clearance to that shown on the as-built tooling documentation. Otherwise, consult an authorized Hoppmann dealer or OEM service technician.

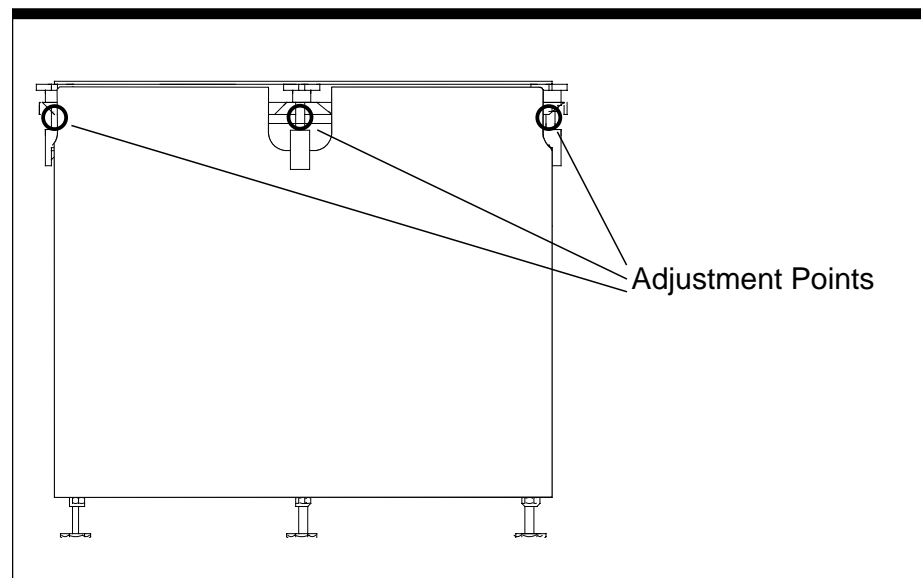

Figure 5-5.
CURRENT STYLE
Backup Ring
Clearance Adjustment

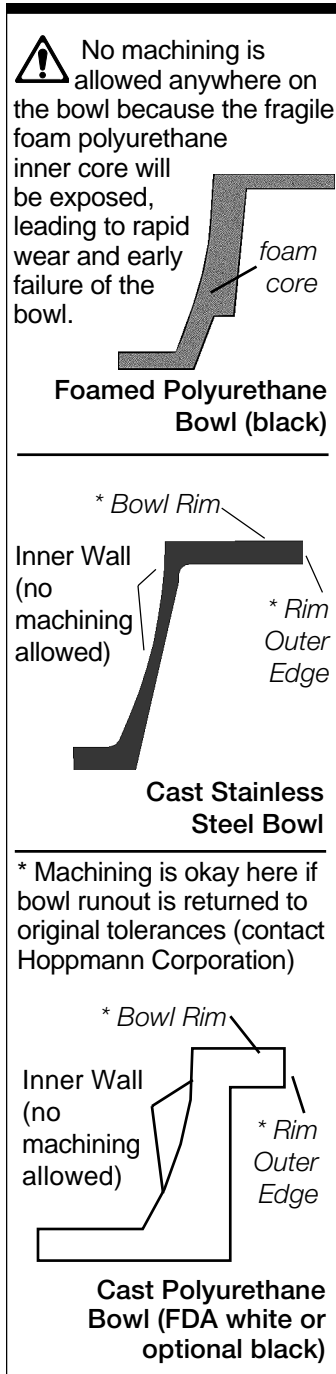

Figure 5-6. Machinable Bowl Surfaces

Removing Bowl For Machining/Replacing

The FR series centrifugal feeder comes with one of two styles of bowl: Standard on the FR-20 is a solid, cast urethane bowl; the FR-30 standard bowl is an injection foam urethane bowl. The FR-30 injection foam urethane bowl should not be modified. If you wish to remove and machine or replace the bowl because of damage, follow the procedure below.

Step 1 Turn Off Power. Turn off power. Remove the FR-20 or FR-30 feeder's bowl.

Step 2 Replace Bowl. If the FR-30 standard bowl has been damaged, replace it with a new bowl. An optional, solid cast urethane bowl is available which can be machined if desired. Mounting hardware is provided with the replacement bowl. Note that unlike the FR-30, all versions of the FR-20 are supplied with a solid case urethane bowl that can be machined if needed.

Do not machine the FR-30 standard injection foam urethane bowl, as modifications will remove the hard outer layer and expose the foam inner core, making the bowl unusable.

Step 3 Machine Bowl (if necessary). Machine the bowl as necessary.

Step 4 Set Bowl Runout. Replace the bowl. After putting the bowl in place, first set the bowl elevation to the correct height $\pm 0.03''$ (0.8 mm). Next, set bowl runout, and check backup ring clearance. Check that all safety covers are in place before returning the feeder into service.

If Parts Jam: General Tips

Step 1 Inspect The Feeder. If parts jam repeatedly, review the following:

- Is the prefeeder delivering too much product? (The prefeeder should deliver only enough product to the feeder to keep the line running at the required rate.)

- ▶ Is the feeder's bowl speed set incorrectly?
- ▶ Is there a changeover procedure you have overlooked?
- ▶ Is the feeder's main air regulator set incorrectly?

Step 2 Inspect Your Product. After checking the feeder, check to see if your product has changed since the last batch:

- ▶ Are they larger? Smaller? A different shape? A different material? Different color? Different quality?
- ▶ If you are orienting freshly molded product, have you made a change in how they are released from the mold? (Are they hotter, drier or stickier, for example?)
- ▶ Finally, if your product has changed, or if you cannot isolate why your product is jamming, contact your direct supplier for assistance.

Troubleshooting Charts

Please refer to the following pages for the troubleshooting charts.

Problem	Possible Cause	Solution
Rate is too low.	Bowl speed incorrect.	<i>Correctly set bowl speed.</i>
	Feeder overloaded.	<i>Check prefeeder speed. Check prefeeder's time delay relay. Check bowl level sensor in feeder.</i>
Bowl and disc turn but parts jam.	Bowl or prefeeder speed incorrect.	<i>Correctly set bowl and prefeeder speed.</i>
	Air off, too low or too high.	<i>Check air flow. Check pressure at main air regulator.</i>
	Incorrect part.	<i>Verify that feeder is correctly set up to run this part.</i>
	Parts are different than last batch.	<i>Verify that feeder was tooled to run this part.</i>
	Tooling or air jets need adjustment.	<i>Refer to your System Operations Manual or contact your direct supplier.</i>
Surface of parts scuffed or dirty.	Particulate in feeder.	<i>Clean bowl and disc.</i>
	Parts already scuffed.	<i>Check upstream machinery.</i>

Figure 5-7. FR-20 & FR-30 Feeder Troubleshooting

Problem	Possible Cause	Solution
Feeder won't run at all.	Power off or disconnected.	<i>Turn on power.</i>
	Downstream machinery is full.	<i>Clear downstream machinery.</i>
	Max level sensor blocked or defective.	<i>Check max level sensor of downstream machinery.</i>
	DC motor speed controller "horsepower" resistor missing; internal settings changed; defective speed controller.	<i>Replace "horsepower" resistor; recalibrate to motor speed controller mfr.'s instructions; or replace DC motor speed controller.</i>
Bowl does not turn.	DC motor brushes worn or motor defective.	<i>Replace DC motor brushes; replace motor.</i>
	Part jammed in feeder.	<i>Disconnect power; locate and remove part; then continue operation.</i>
Bowl and disc cog (jerk when moving).	Torque limiter loose.	<i>Adjust torque limiter.</i>
	DC motor speed controller defective or internal settings changed.	<i>Replace DC motor speed controller or recalibrate to motor speed controller mfr.'s instructions.</i>
Can't adjust bowl speed high enough.	Loose drive belt.	<i>Tighten drive belt.</i>
	DC motor speed controller defective or internal settings changed.	<i>Replace DC motor speed controller or recalibrate to motor speed controller mfr.'s instructions.</i>

Figure 5-8. FR-20 & FR-30 Feeder Troubleshooting, Continued

Spare Parts

6

Notice to Shibuya Hoppmann Customers:

To ensure receiving the right spare part, consult your system operations manual. Refer to the feeder's model and serial number, which was recorded, on the front of this manual when ordering replacement or service parts for your prefeeder. *This information is necessary when ordering replacement parts or service.* The system operations manual lists as-tooled components.

Notice to Dealer & OEM Customers:

Some components listed might have been changed by your dealer or OEM to work better with your application. To avoid ordering the wrong spare part, verify the part number listed in this manual when you place your order with your dealer or OEM.

In North America:

Shibuya Hoppmann Corporation
13129 Airpark Drive, Suite 120
Elkwood, Virginia 22718 • USA
Phone: (540) 829-2564 Toll Free: (800) 368-3582
Fax: (540) 829-1724
www.hoppmann.com • email: spares@hoppmann.com

FR-20 Critical Replacement Parts - ANSI (DC & AC Motors)

Part Number	Description	Page ★	Critical Quantity	
MOTRP . 20HP	1/5 hp, 90VDC Motor	5, 14, 15		1
MOTRAC25HP	AC Motor, 1/4 hp, 42Cz	5, 14, 15	1	
REDUM30P40	Gear Reducer, 40:1, Metric	5, 15	1	1
CNTRKBIC01	Motor Controller, 90VDC	14		1
RESIKB . 100	Resistor, 0.100 OHM	14		1

FR-20 Recommended Replacement Parts - ANSI (DC & AC Motors)

Part Number	Description	Page ★	Quantity	
FT30MR0002	Tooling Clamp - Black - M12		4	4
MFR2000012	Torque Limiter without Sprocket	25	1	1
SPKTTQ2504	Torque Limiter Sprocket, 28T	25	1	1
SPKTM4BS20	#40 Sprocket, 20 Teeth		1	1
CHANCS4051	#40 Chain, 51 Links, 25.5" Long	26, 28	1	1
BRNGFLGM01	Bearing	15	1	1
BRNGPILM01	Bearing, Pillow Block	15	1	1
FEETM12X30	Feet, M12 x 75mm, Zinc	5	2	2

—Not available with this model ★ —For a picture of this part, see these pages

Stainless Steel - AC Motor FR20XXXASA

Stainless Steel - DC Motor FR20XXXDSA

Before ordering, please read the notice at the beginning of this chapter.

FR-30 Critical Replacement Parts - ANSI (DC & AC Motors)

Part Number	Description	Page ★	Critical Quantity	
MOTRP .20HP	1/5 hp, 90VDC Motor	5, 14, 15		1
MOTRMAC033	1/3 hp, 220/380, 3 Phase AC Motor	5, 14, 15	1	
REDUM30P40	Gear Reducer, 40:1, Metric	5, 15		1
REDUM44F40	Gear Reducer, 35:1		1	
CNTRKBIC01	Motor Controller, 90VDC	14		1
RESIKB .100	Resistor, 0.100 OHM	14		1

FR-30 Recommended Replacement Parts - ANSI (DC & AC Motors)

Part Number	Description	Page ★	Quantity	
FT30MR0002	Tooling Clamp - Black - M12		4	4
MFR2000012	Torque Limiter without Sprocket	25	1	1
SPKTTQ2504	Torque Limiter Sprocket, 28T	25	1	1
SPKTM4BS20	#40 Sprocket, 20 Teeth		1	1
CHANCS4057	#40 Chain, 57 Links, 28.5" Long	26, 28	1	1
BRNGFLGM01	Bearing	15	1	1
BRNGPILM01	Bearing, Pillow Block	15	1	1
FEETM12X30	Feet, M12 x 75mm, Zinc	5	2	2

—Not available with this model ★ —For a picture of this part, see these pages

Stainless Steel - AC Motor FR30XXXASA

Stainless Steel - DC Motor FR30XXXDSA

Before ordering, please read the notice at the beginning of this chapter.

FR-20 & 30 Critical Replacement Parts - Metric (AC Motors)

Part Number	Description	Page ★	Critical Quantity	
MOTRP .18HP	.18 hp, 220/380 AC Motor	5, 14, 15		1
MOTRMAC033	1/3 hp, 220/380, 3 Phase AC Motor	5, 14, 15	1	
REDUM30P40	Gear Reducer, 40:1, Metric	5, 15		1
REDUM44F40	Gear Reducer, 35:1		1	

FR-20 & 30 Recommended Replacement Parts - Metric (AC Motors)

Part Number	Description	Page ★	Quantity	
FT30MR0002	Tooling Clamp - Black - M12		4	4
MFR2000012	Torque Limiter without Sprocket	25	1	1
SPKTTQ2504	Torque Limiter Sprocket, 28T	25	1	1
SPKTM4BS20	#40 Sprocket, 20 Teeth		1	1
CHANCS4057	#40 Chain, 57 Links, 28.5" Long	26, 28	1	1
BRNGFLGM01	Bearing	15	1	1
BRNGPILM01	Bearing, Pillow Block	15	1	1
FEETM12X30	Feet, M12 x 75mm, Zinc	5	2	2

—Not available with this model
 ★ —For a picture of this part, see these pages

Stainless Steel - AC Motor FR20XXXASM

Stainless Steel - AC Motor FR20XXXASM

Before ordering, please read the notice at the beginning of this chapter.

Warranty

Hoppmann Corporation warrants that each item of its own manufacture delivered hereunder shall, at the time of delivery and for a period of twelve (12) months thereafter, be free from defects in materials or workmanship; and if any such item shall prove to be defective in material or workmanship under normal intended usage and maintenance during the warranty period, upon examination by Hoppmann Corporation, then Hoppmann Corporation shall repair or replace, at its sole option, such defective item at its own expense; provided, however, that the owner shall be required to ship such defective item, freight prepaid, to Hoppmann Corporation's plant from where it was shipped. The warranty on components not manufactured by Hoppmann Corporation, but a part of the feeder, is limited to the warranty provided by the original manufacturer of said components to the extent, and only to the extent, that such original manufacturer actually honors such warranty. **All warranties hereunder are expressly limited to the repair or replacement of defective items as set forth herein, and in no event shall Hoppmann Corporation be liable for special, incidental or consequential damages by reason of any breach of warranty or defect in material or workmanship. Hoppmann Corporation shall not be responsible for repair or replacement of items which have been subjected to neglect, accident or improper use, or which have been altered by other than authorized Hoppmann Corporation personnel.**

This warranty is in lieu of other warranties, express or implied. All implied warranties, including but not limited to the implied warranties of merchantability and fitness for a particular purpose are hereby excluded.

Scheduled Mechanical Maintenance

Once Every 6 Months

- ▶ Grease the spindle bearings (use grease nipples)
- ▶ Grease the drive chain
- ▶ Grease the sprockets

Performed by (initial) _____ (date) _____

Performed by (initial) _____ (date) _____

Performed by (initial) _____ (date) _____

Performed by (initial) _____ (date) _____

Performed by (initial) _____ (date) _____

Performed by (initial) _____ (date) _____

Performed by (initial) _____ (date) _____

Performed by (initial) _____ (date) _____

Performed by (initial) _____ (date) _____

Performed by (initial) _____ (date) _____

Performed by (initial) _____ (date) _____

Performed by (initial) _____ (date) _____

Performed by (initial) _____ (date) _____

Performed by (initial) _____ (date) _____

Performed by (initial) _____ (date) _____

Performed by (initial) _____ (date) _____

Performed by (initial) _____ (date) _____

Performed by (initial) _____ (date) _____

Performed by (initial) _____ (date) _____

Performed by (initial) _____ (date) _____

Performed by (initial) _____ (date) _____

Performed by (initial) _____ (date) _____

Performed by (initial) _____ (date) _____

Performed by (initial) _____ (date) _____

Performed by (initial) _____ (date) _____

Performed by (initial) _____ (date) _____

Performed by (initial) _____ (date) _____

Performed by (initial) _____ (date) _____

Performed by (initial) _____ (date) _____

Performed by (initial) _____ (date) _____

Maintenance Log. For procedures, see Chapter 4.